

2013



*Innovating Since 1983*

# Thank You

for your interest in MBM's quality products and welcome to our 2013 catalog. Whether you are a new customer or have been an MBM dealer for many years, we appreciate your business! MBM has been serving the auto parts industry for over 30 years. We ship all of our products from our 50,000 sq. ft. facility located in the beautiful mountains of Asheville, NC. We produce all of the parts you see here and stand behind our products!

MBM continues to provide you with top-quality parts at competitive prices. Our staff strives to bring you the top notch service you expect, and we do it every single day.

It's all part of the MBM Advantage. Thanks for your business and we look forward to the continued opportunity to serve you and your company.

John McLeod - President



## MC5621 MASTER CYLINDER



Cast iron Bendix style master cylinder for Mopar 1960s-1970s disc/drum manual or power brake applications. See page 11 for more.

## MC1323 MASTER CYLINDER

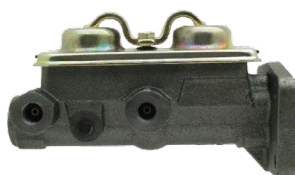

Cast iron Bendix style master cylinder fits 1960s-1970s drum/drum manual or power applications. Includes the original style zinc lid with the hold down bracket. See page 11 for more.

# INTRODUCING

**FOR THE FIRST TIME SINCE THE 70'S A NEW MOPAR BRAKE BOOSTER!**



**PB8536-1**

1966-69 Mopar 2nd Generation B body brake booster. Bendix style trapezoid nose in black.



**PB8536-2**

1970-74 Mopar 2nd Generation B&E body brake booster. Bendix style trapezoid nose in black.

## HWK8536-1



1966-69 B body power brake firewall reinforcement plate.

## HWK8536-2



1970-74 B&E power brake firewall reinforcement plate. Pedal bracket swivel and extension included in kit.

**GIVE US A CALL  
1-800-231-4125**

HOURS: MON-FRI 7:30-4:30 EST.

We put the **POWER** in power brakes!

## BIG BRAKE KIT



### DBK6472BB/DBK6472LXBB

Increased stopping power with our big brake conversion kits. Same applications as our DBK6472 but with a larger 13" rotor and larger caliper.

LX kit shown. Standard kits come with solid rotors and rubber brake hoses.

## 9" FORD TRUCK

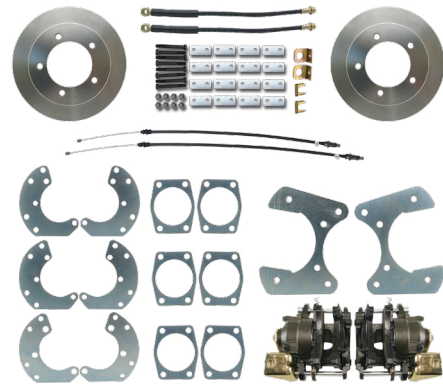

### DBK9TRK

Increased stopping power with our big brake conversion kits. Same applications as our DBK9 but for your trucks! LX kit soon!

## MC1312A MASTER CYLINDER



Aluminum double bail Corvette style GM master cylinder. Chrome lid. 1" bore. Cut your MC weight in half by using durable, light and corrosion resistant aluminum on your brake setup! See page 11 for more.

## RPP7478

Mustang II Power Steering Rack.  
See page 31

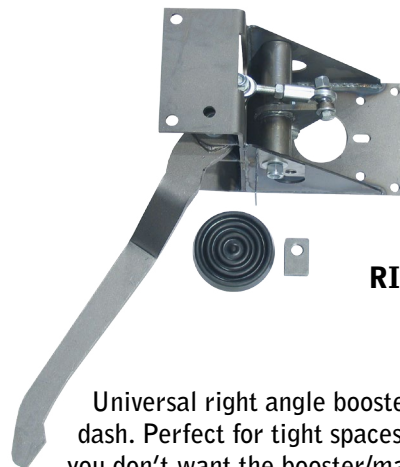

## PRAUD RIGHT ANGLE PEDAL ASSEMBLY

Universal right angle booster bracket for use under dash. Perfect for tight spaces or for builds where you don't want the booster/master in the engine compartment. Comes with weldable threaded tab for pedal pad and rubber pedal pad. Non-coated for easier welding. 7 lbs

## Terms & Conditions of Sale.

### **Shipping**

We ship FOB Asheville, NC and use carriers according to customer request or based on the best price available. You may also use your own account.

### **Ship Notification**

Please provide your e-mail address and we will send a shipping notification containing your carrier tracking number.

### **Damage/Shipping Claims**

Make certain you inspect all packages in the presence of the driver/carrier. If you receive a package that has been damaged or open, you must make a claim with the driver/carrier at that time. All claims of loss, damage, or other destruction must be made by you with the carrier. Save all boxes and packing materials, as the carrier may want to inspect them. We apologize for any inconvenience this might cause. This is a UPS policy and not MBM's. **Any shortages not the fault of the carrier must be reported within five (5) days of receiving the order. Absolutely no exceptions.**

### **Returns**

All returns must be filed within five (5) days of receipt of your order. All returns must be accompanied by a copy of the original invoice. No returns will be accepted after 30 days. No returns on parts that have been altered. Any modification is the customers responsibility and is not subject to a return or credit by MBM. A 20% re-stocking fee will apply to any items that were correctly shipped but are being returned within 30 days. This re-stocking fee may be waived if the return is accompanied by an MBM issued RMA number and a new order with a value \$25.00 more than the returned order. SORRY NO EXCEPTIONS! We will not accept returns that do not have a full explanation of the problem on the RMA form.

### **Exchanges**

Parts that have been painted, marked, have missing pieces (example: check valve or boots), or have been altered in any way are not subject to a credit by MBM.

### **Warranty / Guarantee**

MBM products are guaranteed to be free of defects and workmanship for the **effective lifetime of the product**. This warranty is void in the event of misuse, neglect, improper installation, or misdiagnosis. At our option, we will repair or replace any product found to be defective subject to our inspection and approval.

### **Payment**

For your convenience we accept a variety of payment methods including: Visa, Mastercard, Amex, Discover, Paypal, Cashiers Checks, Money Orders, and Wire Transfers. With approved credit we may also bill net 30 days.

### **Liability**

Neither MBM, our dealers, or agents shall be liable in any way for damage, loss, injury or other claims, resulting from the use, misuse, or inability to use, any of our products. Buyer or user assumes all responsibility of any kind regarding the use or application of our products. MBM's sole responsibility shall be to replace defective parts at their option. After all, the user shall assume all risk and liability whatsoever in connection thereof.

## **Table Of Contents**

New Products	2
Drop Shipping & Private Label Programs	4
Power Brake Boosters	6
Master Cylinders	10
Disc Brake Conversion Kits	12
Rear Disc Brake Kits	15
Hydroboost Repair Kits	16
Proline Booster Conversion Kits	17
Booster Conversion Kits	18
Booster Conversion Kits	18
Power Brake Units	20
Booster Brackets & Pedal Rods	23
Pedal Assemblies	24
Proportioning Valves	26
Proportioning Valve Kits	27
Spindles & Dust Shields	28
Brake Calipers, Brackets & Backing Plates	29
Rotors, Hoses, & Steering Arms	30
Steering, Racks, & Suspension	31
Hardware, Bearings, & Seals	32
Troubleshooting Guide	33
Top Selling Parts	34

### **OPEN & INSPECT IMMEDIATELY!**

**MAKE CERTAIN YOU INSPECT ALL PACKAGES IN THE PRESENCE OF THE CARRIER. IF YOU RECEIVE A PACKAGE THAT HAS BEEN DAMAGED OR OPENED, YOU MUST MAKE A CLAIM WITH THE CARRIER AT THAT TIME. ALL CLAIMS OF LOSS, DAMAGE, OR OTHER DESTRUCTION MUST BE MADE BY YOU WITH THE CARRIER. SAVE ALL PACKING MATERIALS, AS THE CARRIER MAY WANT TO INSPECT THEM. ANY SHORTAGES NOT THE FAULT OF THE CARRIER MUST BE REPORTED WITHIN FIVE (5) BUSINESS DAYS AFTER RECEIVING THE ORDER. ABSOLUTELY NO EXCEPTIONS!**



**THE MBM WEBSITE ALSO PROVIDES YOU WITH EASY ACCESS TO A LOT OF HELPFUL MATERIAL! DEALER APPLICATIONS, ORDER FORMS, RMA FORMS, UP TO DATE INSTRUCTIONS FOR OUR PARTS, MARKETING SUPPORT MATERIALS, FIND IT ALL ON OUR WEBSITE AND MUCH, MUCH MORE!**

# We put the **POWER** in power brakes!

## **MBM DROP SHIPPING PROGRAM**

**Consider the value of being able to have your products shipped directly from the manufacturer to your customer. It ensures a faster delivery to your customer as well as savings for you by reducing the need for keeping high inventory and eliminating freight costs to get that inventory to you so you can sell it. If you haven't considered the value of drop-shipping, now is the perfect time to get into this program.**

- We will always ship to your customer within 3 business days for items that are in stock, but our average time between receiving your order and when it is shipped is only a little over 24 hours!
- All paperwork references **ONLY** your company.
- Send us your company logo and we include it on the packing list (see example); or we can use generic language about the order being shipped from the factory and use your company name and address.
- The UPS shipping label on the white unmarked cartons has your company name in the return address section (see example).
- With a provided e-mail address, you receive a same day carrier email notice of the shipment to your customer with the tracking number. We keep you completely informed in the process.
- How much does this cost?

### **ALL THIS FOR ONLY \$5**

in addition to the standard handling fee of \$7.50.

		Your Company 100 Drop-Ship Ln Prop valve, NC 28866			
Drop Ship For: YOUR COMPANY HERE	Ship To: Your Happy Customer 5555 Brakeway Lane New Booster, NC 28860	PACKING SLIP O-4061 Page # 1			
SALESPERSON Steve Brown	YOUR PO# 8286	SHIP VIA UPS	SHIP DATE 3/30/09	TERMS Prepaid	DATE 3/28/2009
YOUR COMPANY NAME 100 Drop-Ship Ln. Propvalve, NC 28866		20 LBS	1 OF 1		
SHIP TO: ANOTHER SATISFIED CUSTOMER 5555 BRAKEWAY LN. NEW BOOSTER, GA 28833					
		GA 314 0-04			

**YOUR CUSTOMERS CAN RECEIVE FULLY BRANDED ORDERS LIKE THIS FROM YOUR COMPANY TODAY!  
CALL, EMAIL, OR FAX YOUR MBM SALES REPRESENTATIVE WITH YOUR DROP-SHIP ORDER!**

## **MBM PRIVATE LABEL PROGRAM**

**Higher profits and the increase of your hard-won customer loyalty are two of the greatest benefits of selling private-label products. You can make higher profits with your own branded products over the cost of nationally advertised brands, a sure way to increase your bottom line.**

**Are you giving your customers enough reasons to come back to you with repeat business? Consider offering MBM products with your own private label to bring back business through lower prices while increasing profitability.**

- Increase your company's name recognition by offering your own signature products.
- MBM's low pricing helps grow your profits while increasing your company's brand awareness.
- You choose the packaging, so when your order arrives it is ready to ship to your customers.
- MBM can use your labels on our cartons. If needed we can also use your labels that you provide, your part numbers, bar coding (if necessary), and any other information you provide.
- MBM ships your products ready to go, with no re-labeling or other prep work necessary. This reduces your in-house costs and saves you money!
- We can include your promotional material, monthly specials, instruction sheets, or any other collateral material already packed with your product.
- **MBM can do it all for you!**

**These are just a few examples of how MBM private label parts can save you money.  
CALL YOUR MBM SALES REPRESENTATIVE TODAY AND FIND OUT HOW YOU CAN BE A PART OF THE  
PRIVATE LABEL PROGRAM!**

Visit us online at [www.mbmbrakes.com](http://www.mbmbrakes.com)

# POWER BRAKE BOOSTERS

**B**rake Boosters are where MBM began. We started over 30 years ago manufacturing brake boosters. Over the years have grown to be one of the leading manufacturers of new boosters in our industry today!

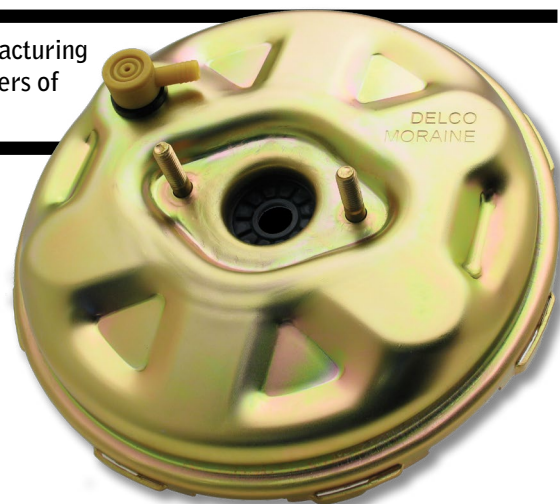

**A**ll of our Delco Moraine booster's are assembled with quality you can count on. That quality is just one reason that MBM is an officially licensed GM Restoration company for 1964-81 Delco Moraine Brake Boosters.



**DELCO MORAINE**  
Original Equipment

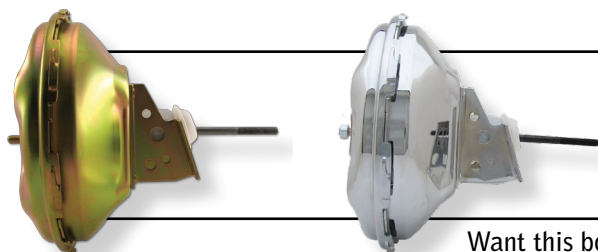

## PB11001

GM A & F Body 1967-72 11" Delco Single Diaphragm Power Brake Booster stamped with Delco Moraine on the Front. Official GM Restoration Part. Also available in chrome as **PB11001C**. Approx. 12lbs.

Want this booster without the stamp? See our PB11003 booster on p. 9

## PB11007

Camaro 1973-81 11" Delco Single Diaphragm Power Brake Booster stamped with Delco Moraine on the Front. Official GM Restoration Part. Also available in chrome as **PB11007C**. Approx. 12lbs.

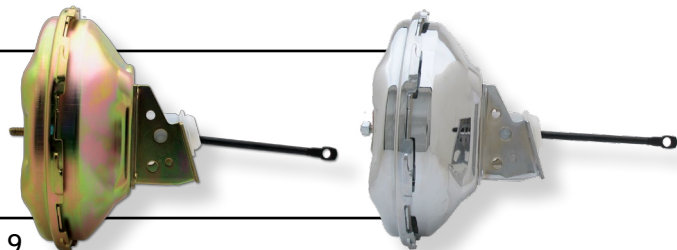

Want this booster without the stamp? PB11006 booster on p. 9

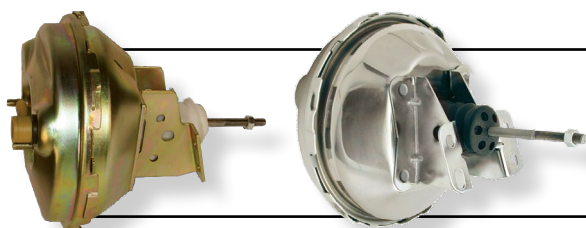

## PB9016

GM A Body 1964-66 9" Delco Single Diaphragm Power Brake Booster stamped with Delco Moraine on the Front. Official GM Restoration Part. Also available in chrome as **PB9016C**. Approx. 7lbs.

Want this booster without the stamp? See our PB9022 booster on p.8

***BRAKE BOOSTERS FOR ANY APPLICATION!***



## PB7001 Universal Series



**PB7001**

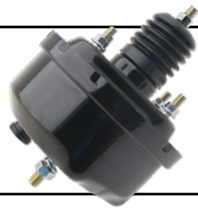

**PB7001PC**

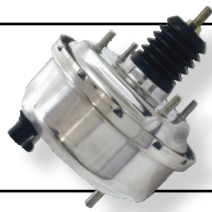

**PB7001C**

7" single diaphragm booster.  
**PB7001** Zinc  
**PB7001PC** Powder Coated  
**PB7001C** Chrome 6lbs.

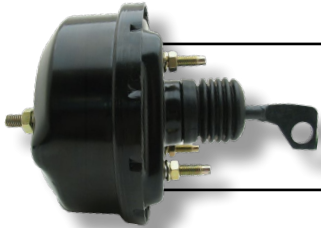

## PB7007

Ford Falcon 1960-65  
 Single diaphragm.  
 5 lbs.

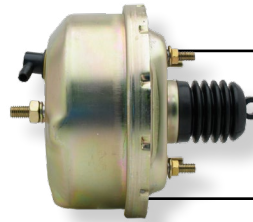

## PB7014

1964-66 Ford Mustang 7" single-  
 diaphragm booster. Long manual pin.  
 7 lbs.

## PB7537 Universal Series

7" dual diaphragm booster.  
**PB7537** Zinc  
**PB7537PC** Powder Coated  
**PB7537C** Chrome  
**PB7537SS** Stainless Steel 7lbs.

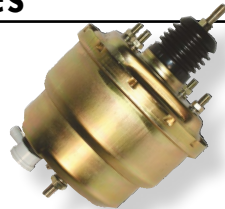

**PB7537**

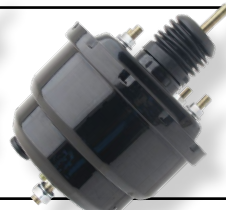

**PB7537PC**

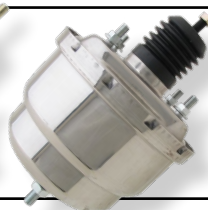

**PB7537C**

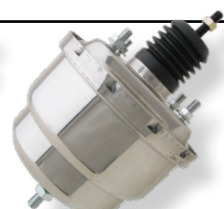

**PB7537SS**

## PB8002

Universal 8" single diaphragm booster.  
 Approx 6 lbs.

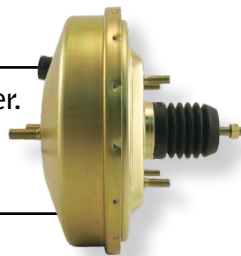

## PB8503

Ford Bronco 8" dual  
 diaphragm booster.  
 Approx 7lbs.

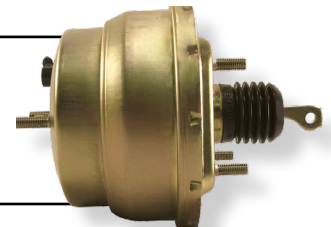

**SPECIAL ORDER ONLY**

## PB8531 Series

Universal 8" dual diaphragm booster.  
**PB8531** Zinc  
**PB8531PC** Powder Coated  
**PB8531C** Chrome  
**PB8531SS** Stainless Steel 8 lbs.

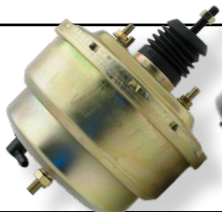

**PB8531**

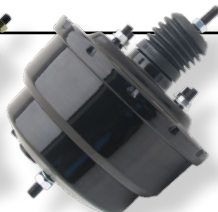

**PB8531PC**

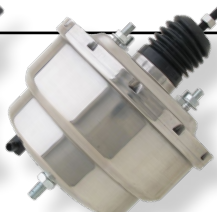

**PB8531C**

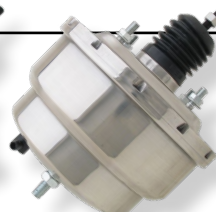

**PB8531SS**

## PB8532

Universal 8" dual-diaphragm  
 booster identical to PB8531  
 and features a manual  
 master cylinder pin. 8 lbs.

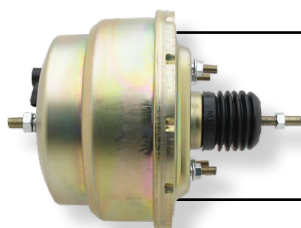

## PB8535

Ground Support  
 Equipment 8" dual-  
 diaphragm booster. 9 lbs.

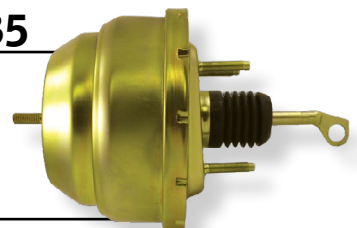

# POWER BRAKE BOOSTERS

## **PB8536-1** *NEW ITEM!*

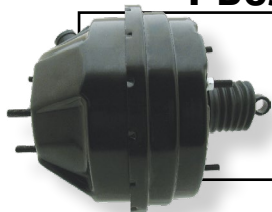

1966-69 B Body Mopar Bendix style trapezoid booster. Reproduction of original. 8 lbs.

## **PB8536-2** *NEW ITEM!*



1970-74 B&E Body Mopar Bendix style trapezoid booster. Reproduction of original. 8 lbs.

## **PB8537**

Universal Bendix style 8" dual-diaphragm booster. 12 lbs.

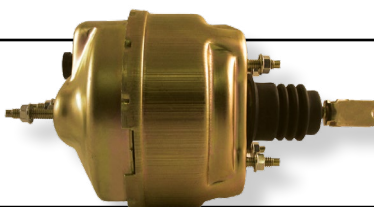

## **PB8538**

Fits Toyota Land Cruiser. 8" dual-diaphragm booster. 8 lbs.

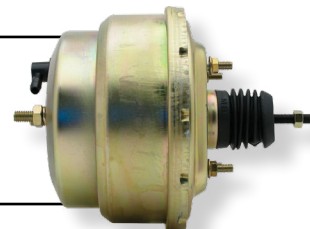

**SPECIAL ORDER ONLY**

## **PB9002B**

Universal 9" single-diaphragm booster. 7 lbs.

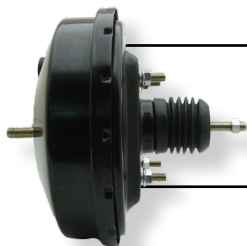

## **PB9007**

Ford Mustang 1967-70. 9" single-diaphragm booster. 7 lbs.

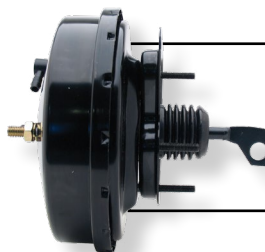

## **PB9011**

Ground Support Equipment 9" single-diaphragm brake booster. 8 lbs.

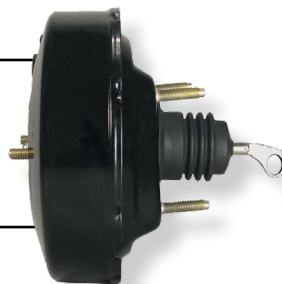

## **PB9013B**

Corvette 1985-91. 9" single-diaphragm booster. Steel construction. 7 lbs.



## **PB9018**

Corvette 1963-67. 9" Delco style single-diaphragm booster w/ riveted bracket. 9 lbs.

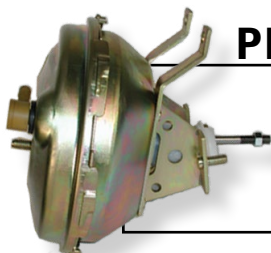

## **PB9018C**

Chrome Corvette 1964-66 9" Delco style single-diaphragm booster w/ riveted bracket. 9 lbs.

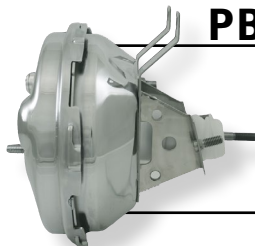

## **PB9021**

GM 1964-66 9" Delco style single-diaphragm booster. Exact copy without bracket. Fits many applications with rod change. 9 lbs.

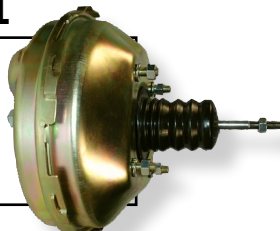

## **PB9021C**

GM 1964-66 9" chrome Delco style single-diaphragm booster. Exact reproduction without bracket. Fits many applications with rod change. 9 lbs

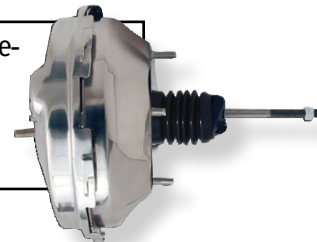

## **PB9022**

GM A-Body 1964-66 9" Delco style single diaphragm booster. Exactly like PB9016 but without Delco-Moraine stamp. 9 lbs

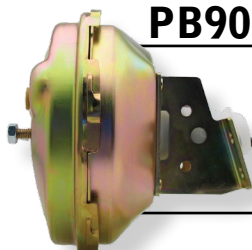

## **PB9029**

Chevy Nova 1964-67 9" Delco style booster. Exact reproduction of original. 3 stud pattern. 9 lbs.

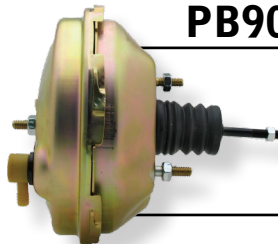



### PB9507

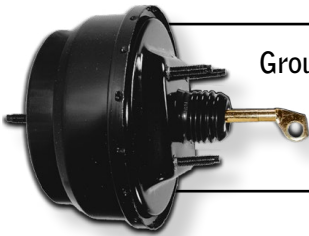

Ground Support Equipment 9" Delco style 9" dual-diaphragm booster. 9 lbs.

### PB9511

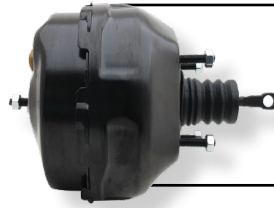

Fits GM 1973-94. 9" Delco style dual-diaphragm booster w/ KZ rod. Exact reproduction of original. 10 lbs.

### PB9512

Fits Corvette 1968-76. 9" Delco style dual-diaphragm booster w/Y7 rod. Replacement for Bendix style booster. Exact reproduction of original. 10 lbs.

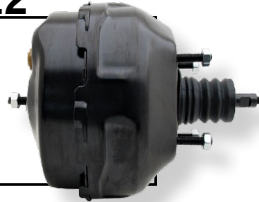

### PB9513

Fits GM 1973-94. 9" Delco style dual-diaphragm brake booster w/ threaded rod. Exact reproduction of original. 10 lbs.



### PB9514

Fits GM 1967-94. 9" Delco style dual-diaphragm brake booster w/ threaded rod. Exact reproduction of original. 10 lbs.

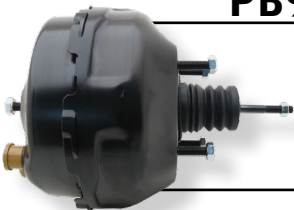

### PB9515

Fits GM 1967-94. 9" Delco style dual-diaphragm brake booster w/ short threaded rod. Exact reproduction of original. 10 lbs.



### PB9520

Fits GM 1973-94 and 1974-80 International Scout and Scout II. 9" Delco style dual-diaphragm brake booster w/ KZ rod. 10 lbs.

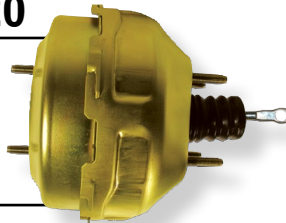

### PB9521

Fits GM 1973-94. 9" Delco style dual-diaphragm booster w/ threaded rod. Exact reproduction of original. 10 lbs.

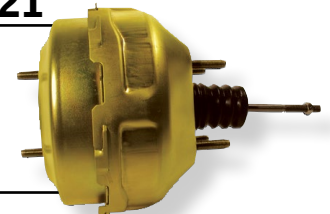

### PB9522

Fits Corvette 1977-82. Delco style 9" dual-diaphragm booster w/ Y7 rod. Exact reproduction of original. 10 lbs

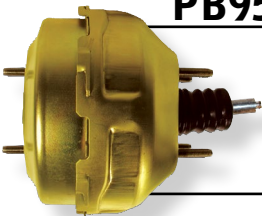

### PB9525

Fits GM 1967-94. 9" Delco style dual-diaphragm brake booster w/ short threaded rod. Exact reproduction of original. 10 lbs.

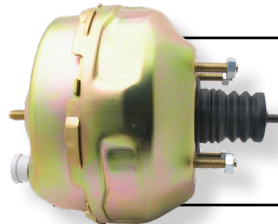

### PB11002

Universal 11" single-diaphragm booster. Has Delco style studs. No bracket included. No Stamp. 12 lbs.

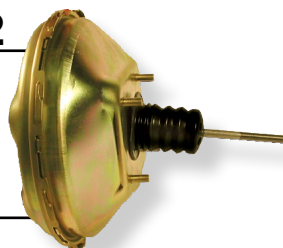

### PB11003

Fits GM A & F-Body 1967-72. Delco style 11" single-diaphragm booster without Delco-Moraine stamp. 12 lbs.

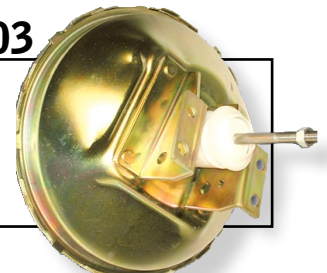

### PB11004

Fits Chevy trucks 1967-72. Delco style 11" single-diaphragm booster w/ KZ rod. No Stamp. 12 lbs.

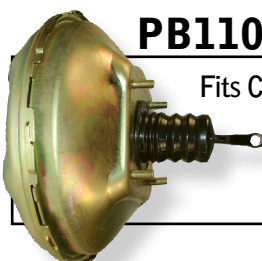

### PB11006

Fits Camaro 1973-81. 11" single-diaphragm booster. Exact reproduction of original. No Stamp. 12 lbs.



Includes PR7881 rod which is 10" in length.

# MASTER CYLINDERS

A high quality master cylinder is critical to proper braking. When you use master cylinders made by MBM you know you are getting a quality part that will meet the demands of your customer, resulting in higher satisfaction and lower returns. We have a large selection of master cylinders to choose from and also carry officially licensed GM Restoration master cylinders.



**GM** Restoration Parts

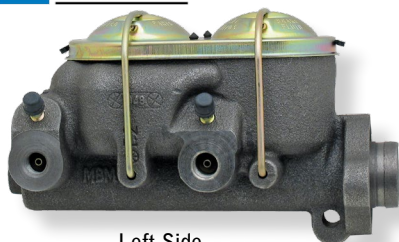

Left Side

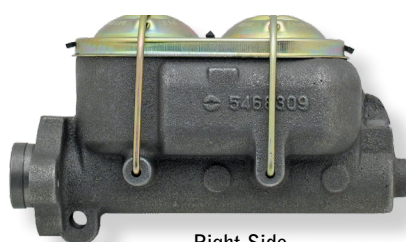

Right Side

## MC309

Licensed GM Restoration master cylinder includes the casting numbers and bleeder screws just like the original! For 1967-77 Dual reservoir; 1-1/8" bore; deep hole; 9/16" and 1/2" ports on left side. 10 lbs.

## MCGW-86

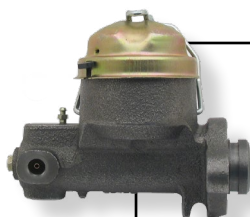

GM Reproduction master cylinder. Single bail design. For 1955-64; 1" bore; 7/16-24 port. For manual or power applications. Exact copy of original. 5 lbs.

## MC2912H



Double bail cast Iron 1-1/8" bore. 9/16" and 1/2" ports on left side. 10 lbs.

## MC2912ACH



Aluminum chrome double bail 1-1/8" bore with 9/16" and 1/2" ports on left and right side. 5 lbs.

## MC2912ACHFT



Aluminum chrome flat-top 1-1/8" bore with 9/16" and 1/2" ports on left side. 5 lbs.

## MC1321H



Double bail cast iron 1" bore with 9/16" and 1/2" ports on each side. 10 lbs.

## MC1321ACH



Double bail aluminum chrome 1" bore with 9/16" and 1/2" ports on each side. 5 lbs.

## MC1321ACHFT



Aluminum chrome flat-top 1" bore with 9/16" and 1/2" ports on left and right side. 5 lbs.

## MC1322H



Double bail cast iron 1" bore with 3/8" ports on both side. 10 lbs.

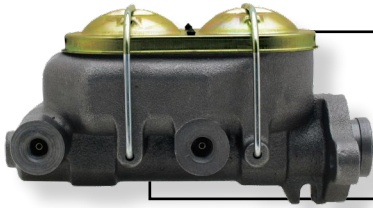

### MC1921H

Double bail cast iron 1" bore with 9/16" and 1/2" ports on left side. 10 lbs.



### MC1312A

Aluminum double bail w/ chrome top 1" bore with four(4) 3/8-24 ports. Includes plugs and piston adaptor. 5 lbs.



### MC7074

Cast iron single bail for disc/drum applications with casting numbers. 1-1/8" bore; 9/16" and 1/2" ports on left side. 10lbs.

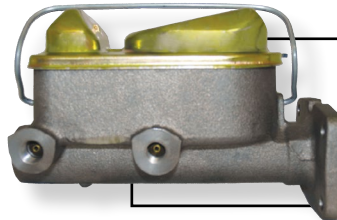

### MC571

Cast iron Mopar B-Body 1973-78. 1-1/8" bore; 9/16" and 1/2" ports on left side. For power brake equipped cars. 10 lbs.



### MC11525

Fits Full-size Ford power brake 1976-79. Single-bail cast-iron dual well master cylinder. 1" bore. 9/16" and 1/2" ports on right side. 10 lbs.

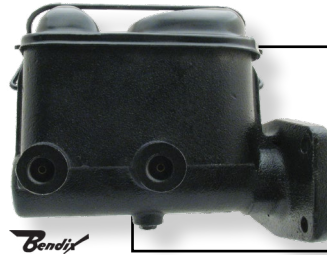

### MC5621 **NEW ITEM!**

Cast iron for Mopar disc applications. 1960-1970's 1.125" bore. Ports are 9/16"-20 INV & 1/2"-20 INV, with internal residual valves. Black only. 8 lbs.



### MC36352H

Cast iron double bail Dual well; 1-1/4" bore; deep hole; 9/16" and 1/2" ports on left side. Exact copy of original. Ground Support Equipment 10 lbs.

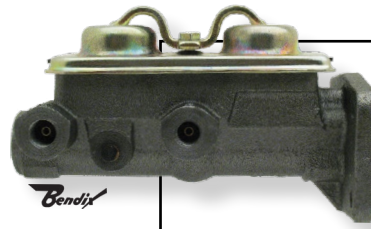

### MC1323 **NEW ITEM!**

Cast iron for Mopar drum/drum applications. 1960-1970's. 1" bore. Ports are 9/16"-20 INV & 1/2"-20 INV, with internal residual valves. Cast finish. 7 lbs.

# SCAN ME!

Scan this QR code with your smart phone to view the hydro-boost repair kit instructions.



Don't have a smart phone or tablet? No worries go to [www.mbmbrakes.com](http://www.mbmbrakes.com) to find instructions, how-to's and other helpful information for installation and troubleshooting!

## BLEEDER KITS

### 345



Master cylinder bleeder kit. Tapered fittings

### 347



Master cylinder bleeder kit. 3/8, 1/2, & 9/16 fittings included

# DISC BRAKE CONVERSION KITS

**D**isc Brake Conversion Kits are some of MBM's top-selling items. The benefits of disc brakes over drum brakes are well documented and the demand is always growing. At MBM we are always developing new kits, and currently have kits that fit a wide variety of cars. In addition we continue to improve our existing disc brake kits so we can provide the highest level of customer satisfaction.

## **CUSTOMIZE YOUR OWN KIT!**

MBM makes it easy to tailor our kits to your customer base. With our kits you can easily add a power booster, master cylinder and proportioning valve kit.

**LOOK FOR THE SYMBOL!**

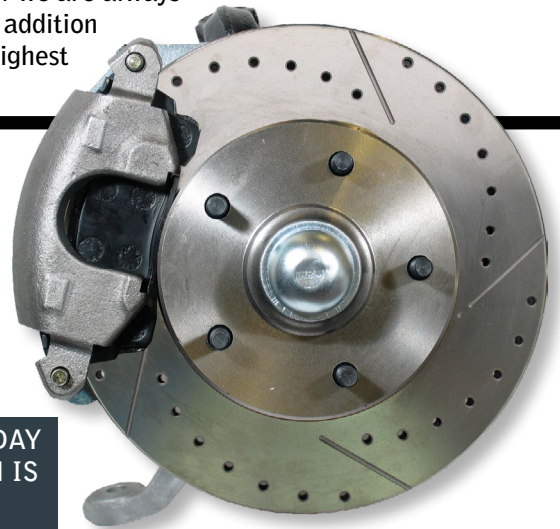

IS YOUR CAR OR TRUCK NOT LISTED HERE? CALL YOUR SALESMAN TODAY TO INQUIRE ABOUT MAKING A CUSTOM KIT FOR YOUR COMPANY! MBM IS INNOVATING PARTS EVERY DAY TO ADD TO YOUR CATALOG!

## **DBK5558**

### **DBK5558LX**

Stock height. Includes 11" rotors, loaded large GM calipers, caliper brackets, brake lines with banjo bolts, vacuum hose with intake manifold fittings, bearings, seals, dust caps, spindle nut and washers and all hardware. Upgrade to the LX kit and receive cross-drilled & slotted rotors and stainless steel braided hoses. 95 lbs.



STANDARD KIT



LX KIT

FULL SIZE CHEVY 1955-58



## **DBK5964**

### **DBK5964LX**

Stock height full wheel kit. Includes 11" rotors, loaded large GM calipers, caliper brackets, brake lines w/ banjo bolts, vacuum hose w/ intake manifold fitting, bearings, seals, dust caps, spindle nuts and washers, and all hardware. Upgrade to the LX kit and receive cross-drilled & slotted rotors and stainless steel braided hoses. 95 lbs.



STANDARD KIT



LX KIT

FULL SIZE CHEVY 1959-64



## **DBK6267**

### **DBK6267LX**

Stock height kit fits 1962-67 X-Body and Nova. Includes 11" rotors, loaded large GM calipers, caliper brackets, backing plates, Nova stock height spindles w/ nuts and washers, brake lines w/ banjo bolts, vacuum hose w/ intake manifold fittings, bearings, seals, dust caps, and hardware kit. Upgrade to the LX kit and receive cross-drilled & slotted rotors and stainless steel braided hoses. 107lbs.



STANDARD KIT

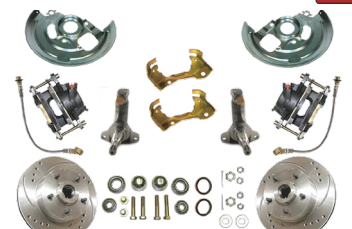

LX KIT

X-BODY



The installation of disc brakes requires the use of 15" wheels. ANY attempt to install a disc brake kit on a 14" wheel is the customers responsibility and is not recommended by MBM.

## DBK6272 DBK6272LX

Fits B-Body 1962-72 & E-Body 1970-74. Full wheel kit includes: 11" rotors, loaded calipers, hubs, backing plates, stock height spindles w/nuts & washers, brake lines w/ banjo bolts, vacuum hose w/ manifold fittings, bearings, seals, dust caps, and hardware. Upgrade to the LX kit and receive cross-drilled & slotted rotors and stainless steel braided hoses. 100 lbs.

MOPAR



STANDARD KIT

LX KIT

## DBK6472 DBK6472LX

Fits F-Body 1967-69, A-Body 1964-72, and X-Body 1968-74. Includes 11" rotors, loaded large GM calipers, caliper brackets, backing plates, stock height spindles w/ nuts & washers, brake lines w/ banjo bolts, vacuum hose w/intake manifold fittings, bearings, seals, dust caps, and hardware. Upgrade to the LX kit and receive cross-drilled & slotted rotors and stainless steel braided hoses. 107lbs.

A,FX BODY



STANDARD KIT

LX KIT

## DBK6568 DBK6568LX

Stock height. Full wheel kit includes: 11" rotors, loaded large GM calipers, caliper brackets, brake lines w/banjo bolts, vacuum hose w/ intake manifold fittings, spindle nuts & washers, bearings, seals, dust caps, and hardware. Upgrade to the LX kit and receive cross-drilled & slotted rotors and stainless steel braided hoses. 95 lbs.

FULL SIZE CHEVY 1965-68



STANDARD KIT

LX KIT

## DBK6970 DBK6970LX

Fits stock height. Full wheel kit includes: 11" rotors, loaded large GM calipers, caliper brackets, brake lines w/banjo bolts, vacuum hose w/ intake manifold fittings, spindle nuts & washers, bearings, seals, dust caps, and hardware. Upgrade to the LX kit and receive cross-drilled & slotted rotors and stainless steel braided hoses. 95lbs.

FULL SIZE CHEVY 1969-70

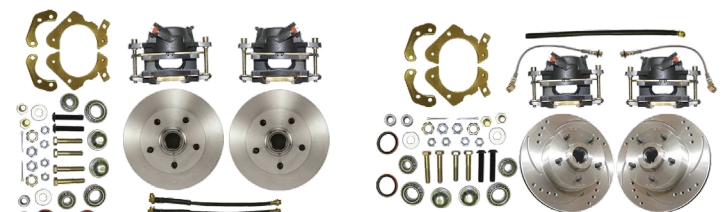

STANDARD KIT

LX KIT

## DBK7478 DBK7478LX

Includes stock height spindles w/ nuts & washers, 11" rotors, large GM calipers, caliper brackets, hubs, brake lines w/ banjo bolts bearings, seals, dust caps, and hardware. Upgrade to the LX kit and receive cross-drilled & slotted rotors and stainless steel braided hoses. 125lbs

MUSTANG II



STANDARD KIT

LX KIT

# DISC BRAKE CONVERSION KITS

## DBK6370CT DBK6370CTLX

Fits 1961-62, 1963-70 Chevy trucks. Upgrade to the LX kit and receive cross-drilled & slotted rotors and stainless steel braided hoses. 100 lbs.

**NEW ITEM!**

**CHEVY TRUCK 1963-70**

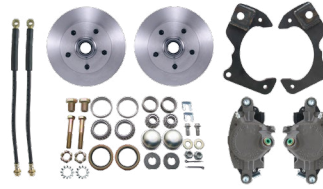

STANDARD KIT



LX KIT

## DROP SPINDLE KITS THESE KITS FEATURE A 2" DROP SPINDLE

## DBK5557HD DBK5557HDLX

Complete 2" drop kit includes: 11" rotors, loaded large GM calipers, caliper bracket, 2" drop spindles w/ nuts & washers, brake lines w/ banjo bolts, vacuum hose w/ intake manifold fittings, bearings, seals, dust caps, and hardware. Upgrade to the LX kit and receive cross-drilled & slotted rotors and stainless steel braided hoses. 95 lbs.

**FULL SIZE CHEVY 1955-57**



STANDARD KIT



LX KIT

## DBK6472D DBK6472DLX

Fits A-Body 1964-72, F-Body 1967-69, X-Body 1968-74 Complete 2" drop kit includes: 11" rotors, loaded large GM calipers, 2" drop spindles w/ nuts & washers, brake lines w/ banjo bolts, vacuum hose w/ intake manifold fittings, bearings, seals, dust caps, and hardware. Upgrade to the LX kit and receive cross-drilled & slotted rotors and stainless steel braided hoses. 100 lbs.

**A, F, & X BODY**



STANDARD KIT



LX KIT

## DBK6472BB DBK6472BBLX

F-Body 1967-69, A-body 1964-72, X-Body 1968-74 Fully Loaded Wheel Kit Includes 13" cross drilled & slotted rotors, loaded large dual-piston GM calipers, caliper brackets, 2" drop spindles, braided stainless steel brake hoses with banjo bolts, bearings, seals, dust caps, spindle nuts, spindle washers and all hardware. 120lbs

**A, F, & X BODY**

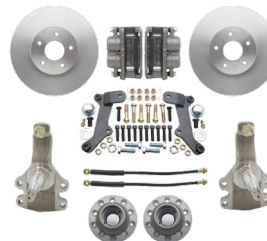

STANDARD KIT



LX KIT

## DISC BRAKE KIT APPLICATIONS

**FULL SIZE:**

Chevy Impala, Chevy Bel Air, Chevy Biscayne, Chevy Del Ray, Chevy 150, Chevy 210.

**A-BODY:**

Chevy Chevelle, Chevy El Camino, Chevy Monte Carlo, Oldsmobile Vista Cruiser, Oldsmobile Cutlass, Oldsmobile 442, Oldsmobile F-85, Pontiac Tempest, Pontiac LeMans, Pontiac GTO, Buick Special, Buick Skylark.

**F-BODY:**

Chevy Camaro, Pontiac Firebird

**X-BODY:**

Chevy Nova

**Mopar:**

Belvedere (B), Challenger (E), Charger (B), Coronet (B), Cuda (E), GTX (B), Satellite (B), Road Runner (B).

# REAR DISC BRAKE KITS

## DBK1012 / DBK1012FS DBK1012LX / DBK1012LXFS

Complete rear disc brake kit for non-staggered shock F-Body 1967-69, A-Body 1964-72, X-Body 1968-74. Includes 11" rotors, loaded calipers, caliper brackets, hardware & spacers, brake lines & brackets, and e-brake cables. Upgrade to the LX kit and get cross-drilled & slotted rotors and stainless steel braided hoses. Also available in FS kits for full size cars 1955-64. 65 lbs.

REAR

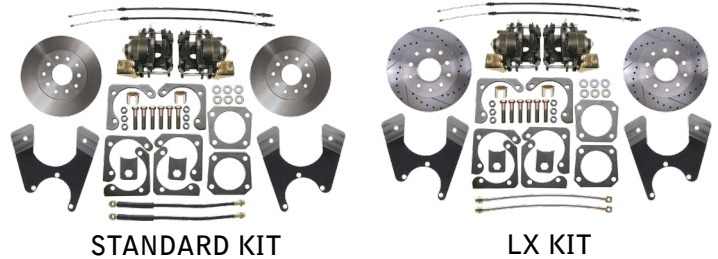

STANDARD KIT

LX KIT

## DBK1012S / DBK1012SLX

Complete rear disc brake kit for staggered shock F-Body 1967-69, A-Body 1964-72, X-Body 1968-74. Includes 11" rotors, loaded calipers, caliper brackets, hardware & spacers, brake lines & line brackets, and emergency brake cables. Upgrade to the LX kit and receive cross-drilled & slotted rotors and stainless steel braided hoses. 65 lbs.

REAR - STAGGERED



STANDARD KIT

LX KIT

## DBK9 / DBK9LX

Fits pre-1980 Ford passenger and light truck 9" rear-end. Includes brackets and flanges that fit the three most popular sizes of the small bearing 9" rear end (3-3/8" x 2", 3-1/2" x 2-3/8", 3-9/16" x 2"), 11" GM rotors, loaded calipers, caliper brackets, hardware & spacers, brake lines & line brackets, and emergency brake cables. Upgrade to the LX kit and receive cross-drilled & slotted rotors and stainless steel braided hoses. 64 lbs.

FORD 9" REAR-END

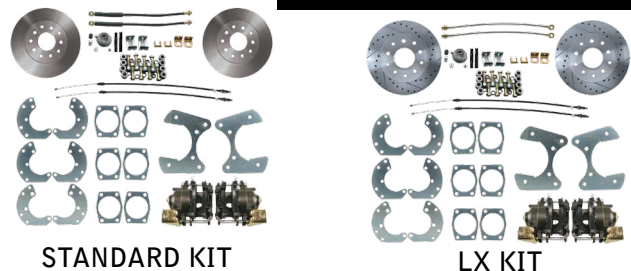

STANDARD KIT

LX KIT

## DBK9TRK **NEW ITEM!**

Pre-1987 Ford 9" rear-end light truck to disc brake performance. Fits the three most popular sizes of the 9" rear end (3-3/8" x 2", 3-1/2" x 2-3/8", 3-9/16" x 2"). Includes 5 on 5 1/2 bolt pattern rotors. Standard only. LX coming soon.

REAR



STANDARD KIT

ASK ABOUT THE LX KIT. COMING SOON!

## DBK834 / DBK834LX

An easy to install, bolt on solution for upgrading the popular Mopar 8 3/4" rear end to disc brake performance. Upgrade to the LX kit and receive cross-drilled & slotted rotors and stainless steel braided hoses. 65 lbs.

MOPAR 8 3/4" REAR-END



STANDARD KIT

LX KIT

### E-BRAKE CABLES FOR DBK834/DBK834LX KIT

Part #	Length	Application
EBCRE-561	34 3/4"	1967-76 Chrysler/Dodge A-Body &
EBCRE-562	73 3/4"	1967-74 Chrysler/Dodge A-Body
EBCMRE-552A	35"	1970-74 Chrysler/Dodge E-Body &
EBCMRE-553	72 3/4"	1970-74 Chrysler/Dodge E-Body
EBCMRE-512	35 5/8"	1966-70 Chrysler/Dodge B-Body &
EBCMRE-513	75 3/4"	1966-70 Chrysler/Dodge B-Body

Due to the wide variety of cars the DBK834 kit is compatible with, there is no single length E-Brake cable which will work universally. MBM overcomes this problem by offering several different sizes of cables for separate purchase, so you can tailor fit it to your application!

**BIG BRAKE KITS**

**DBK6472BB  
DBK6472BBLX**

F-Body 1967-69, A-body 1964-72, X-Body 1968-74 Full Wheel Kit Includes 13" slotted rotors, loaded large dual-piston GM calipers, caliper brackets, backing plates, 2" drop spindles, braided stainless steel brake hoses with banjo bolts, bearings, seals, dust caps, spindle nuts, spindle washers and all hardware. 120lbs

**NEW ITEM!**

**FRONT 2" DROP**



STANDARD KIT

LX KIT

**HYDRO-BOOST & HYDRO-VAC REPAIR KITS**

**Kit 2335**

2512335 Hydro-Vac repair kit.  
1 lb.



**Kit 501**

2771004 Universal Complete repair kit.  
Includes metal components.  
1 lb.



**Kit 50**

2771004X Universal. Rubber Only. Repair Kit.  
1 lb.



**TECH** NOTES

**HOW OFTEN SHOULD I FLUSH MY BRAKE SYSTEM?**

It's good practice to flush out your brake system every two years. Brake fluid readily absorbs moisture, and this moisture will cause rust. This type of corrosion can lead to brake failure by freezing wheel cylinders and calipers.

You can always find our most up-to-date instructions for our products available for download at our website [www.mbmbrakes.com](http://www.mbmbrakes.com). Look in the "downloads" section, or scan the QR code to go right to our tech support page.

**SCAN**  
**HERE**





We put the **POWER** in power brakes!



**POWER BRAKE CONVERSION KITS**

**H**igh quality show look with our premium powder coated parts. Upgrade yourself to the latest non-corrosive line on the market. Our complete power brake conversions include a master, booster and necessary brackets for an easy installation. We are designing new conversion kits every day! Contact your salesman today!

**PL5564**

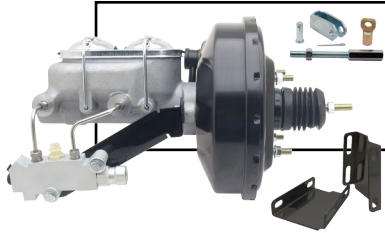

Chevy Trucks 60-66; brackets 9" booster, pedal rod extension and clevis. Prop valve kit available.

**PL7486**

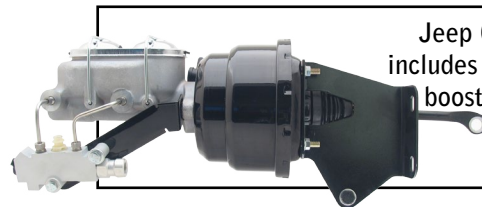

Jeep CJ 7 from 74-86; includes brackets, 7" dual booster. Prop valve kit available.

**PL6472**



Chevelle 64-72 & Camaro 67-69; 7" dual booster; brackets clevis and extension. Prop valve kit available.

**PL6466A**

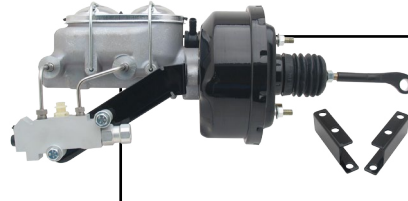

Mustang 64-66 with Automatic Transmission; 7" single booster with brackets and extension. Prop valve kit available.

**PL4754**



Ford Cars 57-72 with 7" dual boosters. Prop valve kit available.

**PL5772**

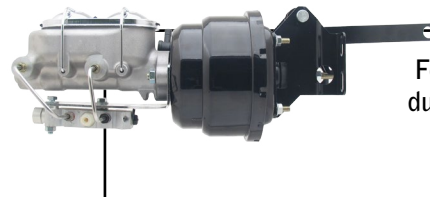

Ford Cars 57-72 with 7" dual boosters. Prop valve kit available.

**PL-6001**

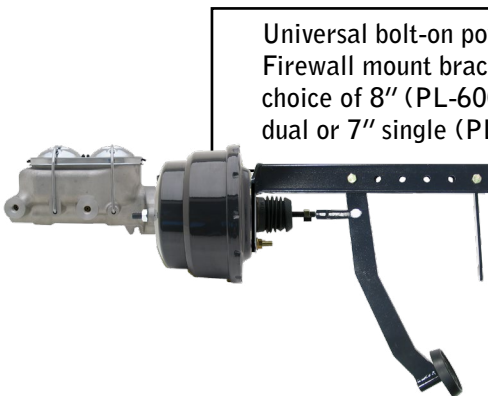

Universal bolt-on power unit. Includes: Firewall mount bracket, master cylinder, choice of 8" (PL-6001) dual, 7" (PL-6002) dual or 7" single (PL-6003) booster.

Pedal pivot point adjusts to 7", 8.5", 10", 11.5", & 13"

**PL2831**



Universal bolt-on power unit. Includes: Frame mount bracket and master cylinder. Available with 7" dual or 7" single booster.

**IF YOU DON'T SEE WHAT YOU WANT HERE IN OUR PROLINE SERIES, CONTACT US WITH YOUR IDEAS AND SUGGESTIONS!**

# BOOSTER CONVERSION KITS

**E**ven perfectly operating manual brakes can't achieve the performance of a power brake system. MBM makes conversion to a power system easy, with ready-to-go kits that reduce part number guess-work while increasing safety and performance.

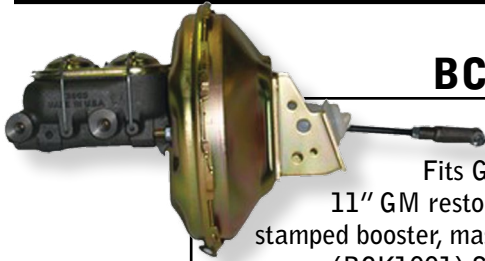

## BCK1000-11003

Fits GM 1964-72. Includes 11" GM restoration Delco Moraine stamped booster, master cylinder & clevis. (BCK1001) Stamp optional. 23 lbs.



## BCK1005-8531

Fits 1955-70. Includes 8" dual diaphragm booster, master cylinder, booster bracket, pedal rod extension and clevis. 23 lbs.

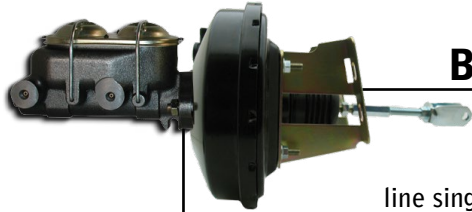

## BCK1001-9002

Fits GM 1964-72. Includes 9" slim-line single diaphragm booster, master cylinder, bracket, pedal rod extension & clevis. 23 lbs.

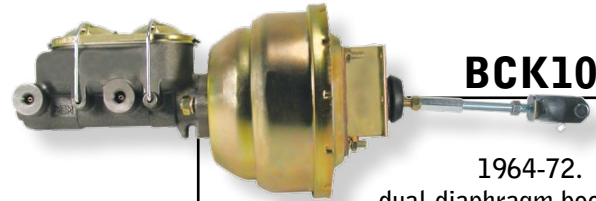

## BCK1006-8531

Fits GM 1964-72. Includes 8" dual-diaphragm booster, master cylinder, bracket, pedal rod extension & clevis. 23lbs

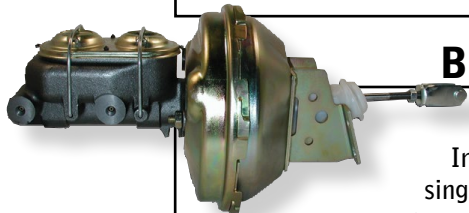

## BCK1001-9022

Fits GM 1964-72. Includes 9" Delco style single diaphragm booster, master cylinder, bracket, pedal rod extension & clevis. 23 lbs.

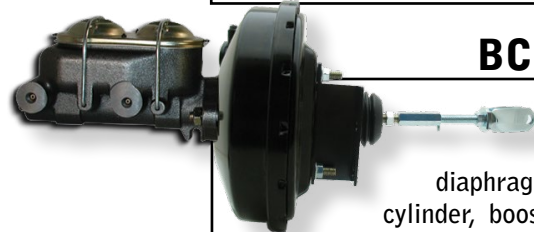

## BCK1006-9002

Fits 1955-70. Includes 9" single diaphragm booster, master cylinder, booster bracket, pedal rod extension and clevis. 23 lbs.

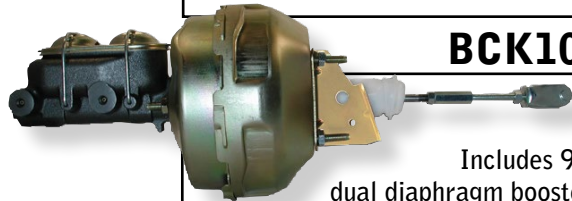

## BCK1002-9521

Fits GM 1964-79. Includes 9" Delco style dual diaphragm booster, (gold can) master cylinder, bracket, pedal rod extension & clevis. 23 lbs.

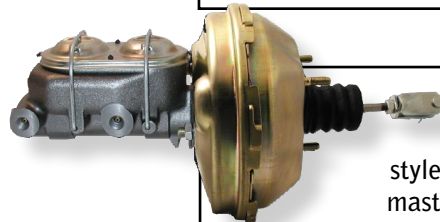

## BCK1033-9029

Fits Chevy Nova 1962-67. Includes 9" Delco style single diaphragm booster, master cylinder, & clevis. 23lbs

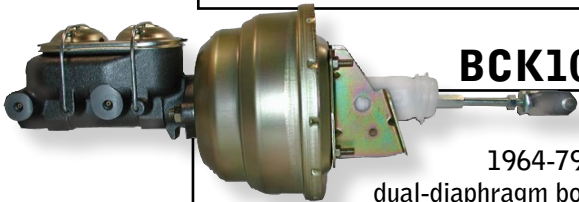

## BCK1003-8531

Fits GM 1964-79. Includes 8" dual-diaphragm booster, master cylinder, bracket, pedal rod extension & clevis. 23 lbs.

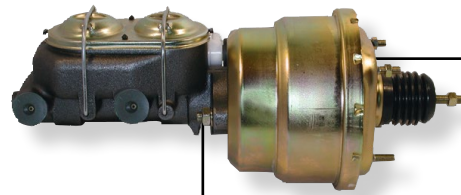

## BCK5001

Universal application. 7" dual diaphragm booster, master cylinder. 23 lbs.

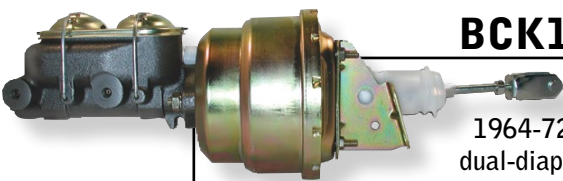

## BCK1004-7537

Fits GM 1964-72. Includes 7" dual-diaphragm booster, master cylinder, bracket, pedal rod extension & clevis. 23lbs

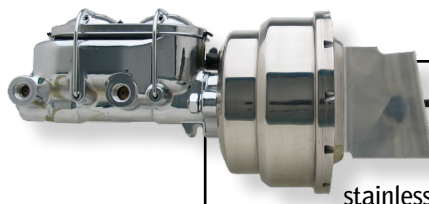

## BCK5002

Universal street rod & Chevy car 1955-70. Includes 7" dual-diaphragm polished stainless steel booster, chrome master cylinder, stainless steel bracket. 23lbs

## BCK5003

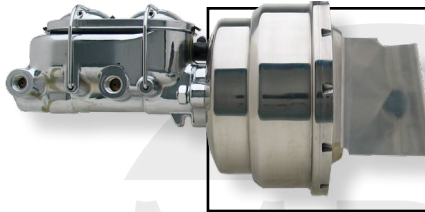

Universal street rod. Includes dual 8" polished stainless steel booster, stainless steel bracket and chrome master cylinder. 23 lbs.

**TOP  
SELLER!**

## DB119

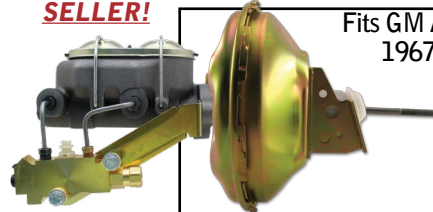

Fits GM A-body's 1964-72, F- Body's 1967-69, & X-body 1968-74. Kit includes an 11" Delco style power booster, a dual reservoir master cylinder and proportioning valve kit for disc/drum.

## BCK5004

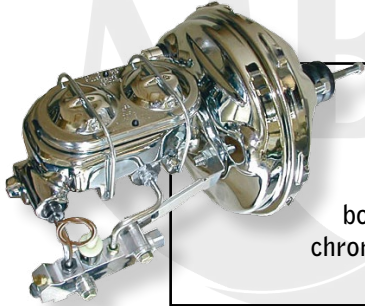

Fits GM A-Body 1964-72, F-Body 1967-72, X-Body 1968-74. Kit includes: 11" Delco style single-diaphragm booster, chrome master cylinder, chrome proportioning valve kit and proportioning valve plumbing.

## DB120-120D

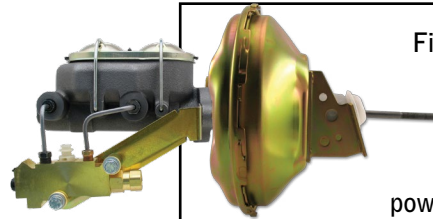

Fits GM A-body's 1964-72, F- Body's 1967-69, & X-body 1968-74. includes 11" Delco Moraine stamped power booster, dual reservoir master cylinder, casting numbers, bleeder screws and proportioning valve kit for disc/drum.



## BCK5005

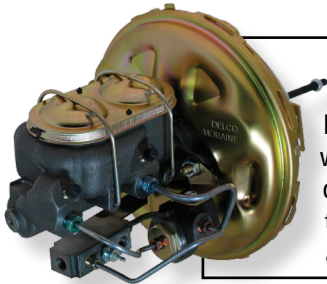

11" Delco-Moraine stamped single diaphragm booster, a GM Restoration cast iron master cylinder with casting numbers. Prop valve and distribution block crafted to look like the original equipment and 4 lines to accommodate multiple setups. 26lbs.

## BCK8536-1

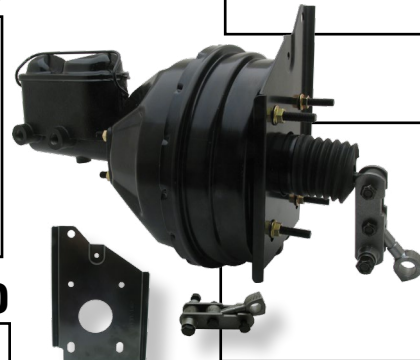

Mopar Bendix style trapezoid nose booster fits 1966-69 B bodies. Includes the 4 stud disc/drum 1.125" bore master in black. To be used with HWK8536-1. 16 lbs.

## DB114/DB114D

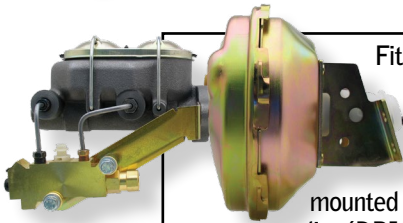

Fits 1964-1966 Chevy Chevelle. Utilizes an MC1322H dual-well master cylinder and 9" diaphragm booster. Comes with side-mounted prop valves for use with disc/disc (DB114D) or disc/drum (DB114).

## BCK8536-2

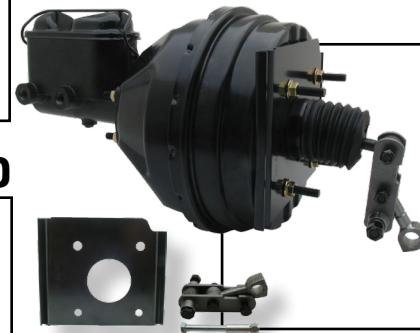

Mopar Bendix style trapezoid nose booster fits 1970-74 B&E bodies. Includes the 4 stud disc/drum 1.125" bore master cylinder in black. To be used with HWK8536-2. 16 lbs.

**TOP  
SELLER!**

## DB116/DB116D

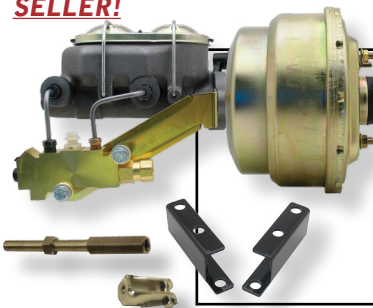

Fits 1955-57 Chevy. Utilizes a dual-well master cylinder and 8" dual-diaphragm booster. Includes side-mounted prop valves for use with disc/disc (DB102D) or disc/drum (DB102). Also includes pedal rod extension, booster bracket and clevis.

## BCK8536-1D



Mopar Bendix style trapezoid nose booster that fits 1966-69 B bodies. Includes the 4 stud drum/drum 1" bore master cylinder. To be used with HWK8536-1. 15 lbs.

## DB117-DB117D

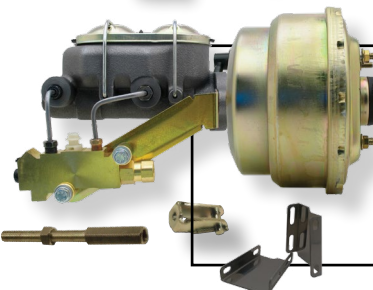

Fits 1958-70 Full Size Chevy. Complete power brake conversion assembly featuring a 8" dual power booster, a dual reservoir master cylinder and proportioning valve kit for disc/drum.

# POWER BRAKE UNITS

**W**hether bringing an existing manual brake system back to original performance or upgrading to a power system, MBM has your customers covered with our complete power and manual brake units.

## PBUPRAUM

Universal bolt-on manual pedal assembly. Includes bolt-on pedal assembly and master cylinder. 23 lbs.

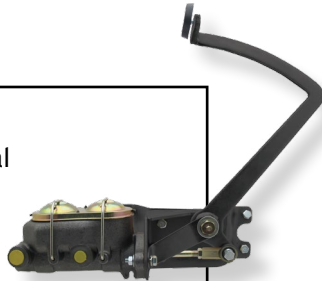

## PBUFT12504

Fits 1st Generation Ford Broncos. Includes a bendix style booster with Ford style master. 30 lbs.

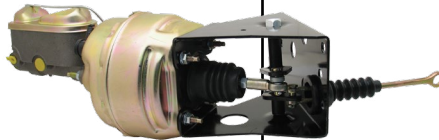

## PBUU2831-7S

Universal bolt-on power unit w/ bracket. 7" single-diaphragm booster, master cylinder and pedal assembly. 29 lbs.

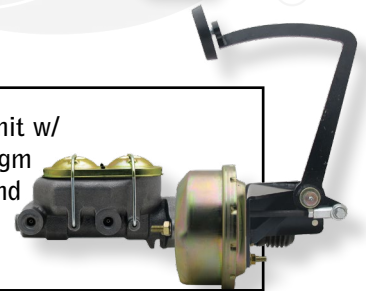

## PBUU2831

Universal bolt-on power unit w/ bracket. 7" dual-diaphragm booster, master cylinder and pedal assembly. 30 lbs.

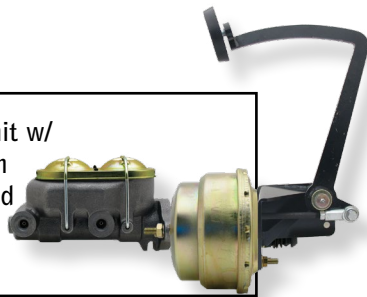

## PBUF3334-7S

**SPECIAL ORDER ONLY**

Fits Ford 1933-34. Includes: 7" single-diaphragm booster, master cylinder and pedal assembly. 26 lbs.

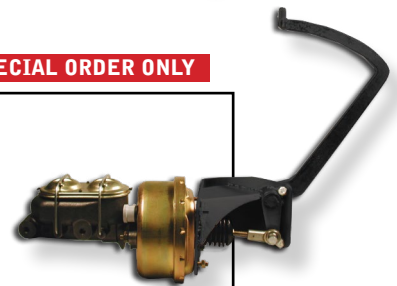

## PBUF3540

Fits Ford 1935-40. Includes: 7" dual-diaphragm booster, master cylinder and pedal assembly. 27 lbs.

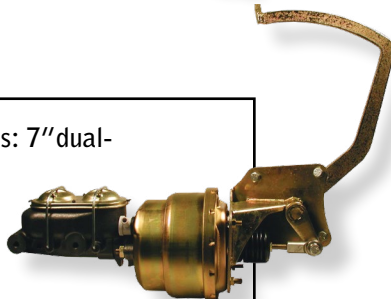

## PBUF3540-7S

Fits Ford 1935-40. Includes: 7" single-diaphragm booster, master cylinder and pedal assembly. 26 lbs.

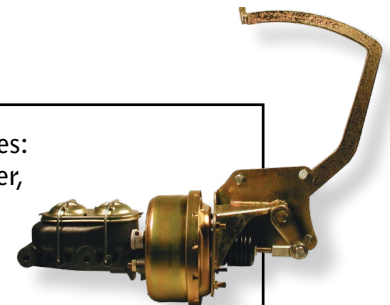

## PBUF4148

Fits Ford 1941-48. Includes: 7" dual-diaphragm booster, master cylinder, and pedal assembly. 29 lbs.

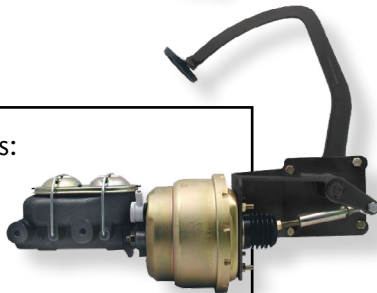

## PBUFT4752

Fits Ford truck 1947-52. Includes: 7" dual-diaphragm booster, master cylinder, booster bracket, and pedal rod extension. 23 lbs.

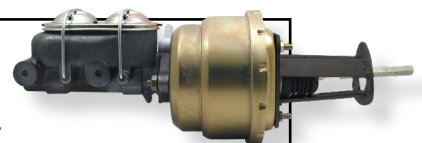

## PBU6001

Universal bolt-on power unit. Firewall mount booster bracket and master cylinder. 8" dual **PBU6001**, 7" dual **PBU6002** 7" single **PBU6003**. Pedal pivot point is adjustable from 7" to 13". 30 lbs



## PBUJ7486/ PBUJ7486D

Fits Jeep CJ 1974-86. Disc/ Drum (**PBUJ7486**) Disc/ Disc (**PBUJ7486D**) 8" dual-diaphragm booster w/ bracket assembly, & master cylinder. 27 lbs.



## PBUC4954

Fits Chevy 1949-54. Includes: 7" dual-diaphragm booster, master cylinder & pedal assembly. 30 lbs.

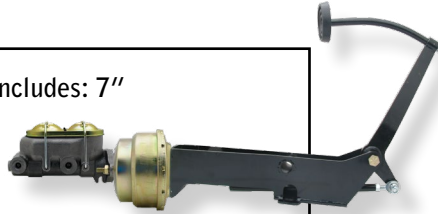

Designed for automatic cars.

## PBUC4954-7S

Fits Chevy 1949-54. Includes: 7" single diaphragm booster, master cylinder & pedal assembly. 30 lbs.

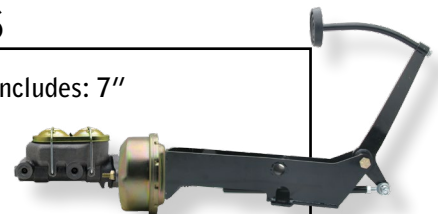

Designed for automatic cars.

## PBUFMFT5356A

Fits Ford truck 1953-56. Includes 7" dual-diaphragm booster. Master Cylinder and pedal assembly. 29 lbs.

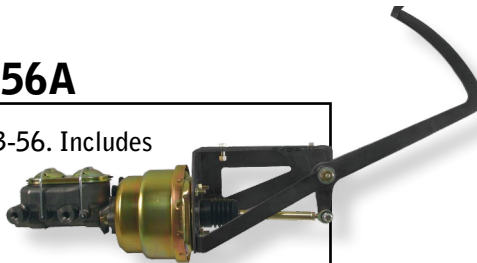

## PBUFT5772

Fits Ford truck 1957-72. Includes: 7" dual-diaphragm booster, master cylinder, mounting bracket and pedal rod extension. 26 lbs.



## PBUF6466A FOR AUTOMATIC TRANSMISSION ONLY

Fits Fords Mustang 1964-66. Includes: 7" single-diaphragm booster & bracket, drum brake master cylinder & pedal assembly. 19 lbs

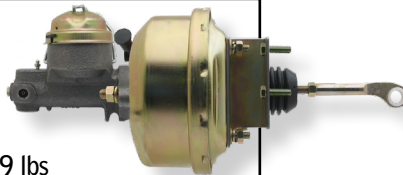

ALSO AVAILABLE WITH 7" DUAL AS PBUF6466B OR CHROME BOOSTER AS PBUF6466C

## PBUF6466 FOR MANUAL TRANSMISSION ONLY

Fits Fords Mustang 1964-66. Includes: 7" single-diaphragm booster & bracket, drum brake master cylinder & pedal assembly. 19 lbs

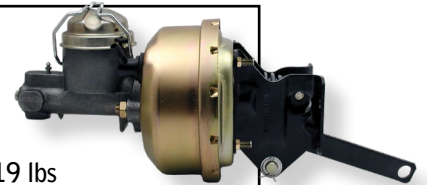

## PBUF6466D FOR AUTOMATIC TRANSMISSION ONLY

Fits Fords Mustang 1964-66. Includes: 7" single-diaphragm booster & bracket, Ford style single bail master cylinder. 19 lbs

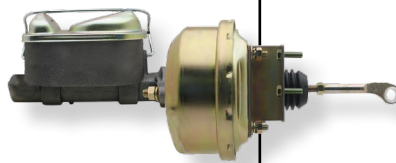

## PBUF5772

Fits Ford Mercury 1957-72. Includes: 8" dual-diaphragm booster, master cylinder, booster bracket and pedal rod extension. 26 lbs.



\*Note: will not fit 292/312 engines with original exhaust manifolds or big block cars from 1957-59

## PBU9007MC

Ford Mustang/Cougar 1967-70 9" single-diaphragm Bendix style booster with firewall bracket & master cylinder. 20 lbs. See p. 25 BPAF6769PED

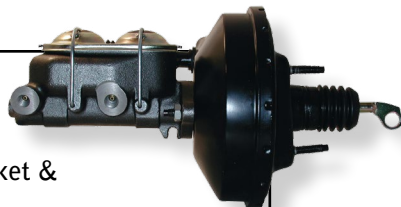

## PBUC5564

Fits full size Chevy car 1955-64\*. Includes: 8" dual-diaphragm booster w/bracket, master cylinder & pedal assembly. 21 lbs.

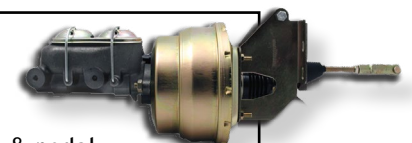

\* Includes - Bel Air, Impala, Biscayne, 150, 210

# POWER BRAKE UNITS

## PBUFMCT4754

Fits Chevy truck 1947-54. Includes: 7" dual-diaphragm booster, master cylinder, & frame mount pedal assembly. 29 lbs.

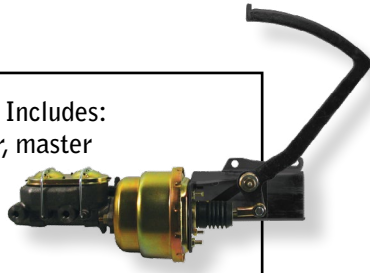

## PBUFMFT5356A

Fits Ford truck 1955-59. Includes: 7" dual-diaphragm booster, master cylinder & pedal assembly. 29lbs.

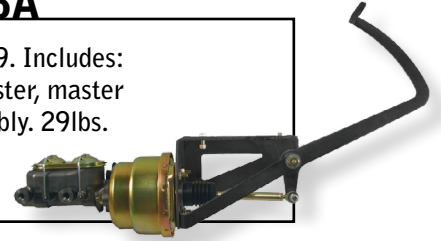

## PBUFMCT5559

Fits Chevy truck 1955-59. Includes: 7" dual-diaphragm booster w/ pedal, master cylinder, & pedal rod extension. 25 lbs.

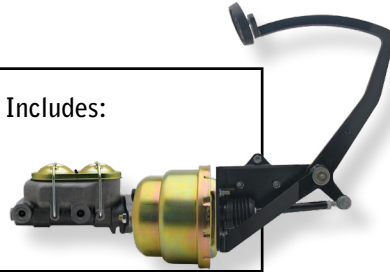

## PBUCT6072

Fits Chevy truck 1960-66. Includes: 9" single-diaphragm booster w/ bracket, master cylinder, & pedal rod extension. 29 lbs.

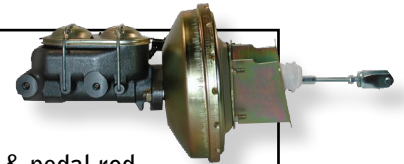

## PBUCT6772

Fits Chevy truck 1967-72. Includes: 8" dual-diaphragm booster w/ bracket, master cylinder, & pedal rod extension. 26 lbs.



## PBU9512

Fits Corvette 1968-76. Kit includes: 9" dual-diaphragm Delco style booster (black can) & master cylinder. 16 lbs.



## PBU9018

Fits Corvette 1963-67. Exact duplicate of original. Includes: 9" single-diaphragm booster & master cylinder. 19 lbs.

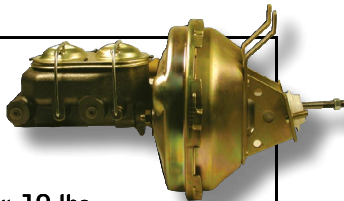

## PBU9013

Fits Corvette 1985-91. Exact duplicate of original. Includes: 9" single-diaphragm Delco style booster w/ bracket, master cylinder, & pedal rod extension. 13 lbs.

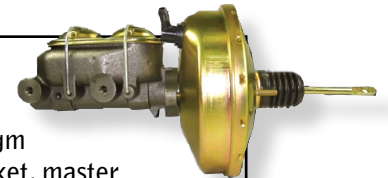

## PBU9522

Fits Corvette 1977-82. Includes: 9" dual-diaphragm delco style booster (gold can) & master cylinder. 16 lbs.

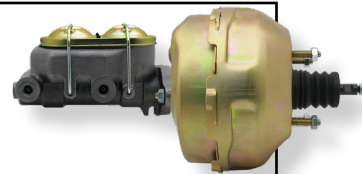

## PBUP6570

Fits Dodge/Plymouth 1965-70 A-Body, 1965-74 B-Body, & E-Body. Includes: 8" dual-diaphragm booster w/bracket, & master cylinder. 27 lbs.

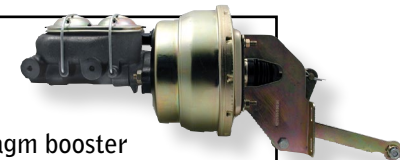

## CUSTOMER SERVICE IS OUR TOP PRIORITY!

Just wanted to let you know how much we appreciate David Ziller and his help with the MBM products. We would like to recognize and thank David for his valuable assistance. When we have a question, he is always quick to respond. That is very important to us so that we can get back to the customer quickly. Our customers are thankful for the quality products MBM carries, as well as the great prices. Carolina Classic Trucks thanks David and the MBM team for a job well done.

~ Carolina Classic Trucks

Only for use when converting a manual car to power. O.E. Power cars require firewall plate modification in order to work with this kit..

## BOOSTER BRACKETS

**650**



Fits GM 1964-72. 1 lb.

**650-SS**



Same as 650, but made of durable stainless steel. 1 lb.

**PBB7004B**



Fits GM 1955-58  
Universal Straight. 1 lb.

**PBB7004BSS**

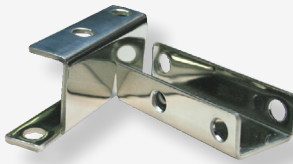

Same as PBB7004B, but made of stainless steel. 1 lb.

**CT6372BK**

**651A / 651A-SS**

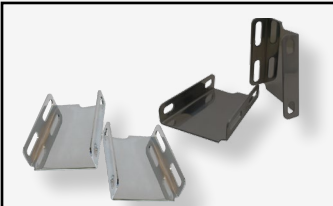

Fits GM 1955-64. Also available in stainless. 1 lb.

**MCBAP**

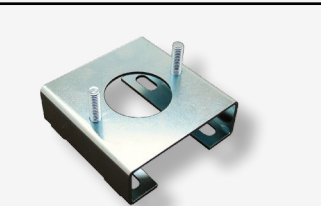

Manual to Power conversion adaptor. 1 lb.

**B7495**

Fits 1974-95 Jeep. Booster bracket. 5 lbs.



**BOOSTER BRACKETS ALSO AVAILABLE IN BLACK POWDERCOAT. ASK YOUR MBM SALES REP**



## PEDAL RODS

	<p><b>TRKPRE</b> Universal truck pedal rod extension. 3/8" x 24". 1 lb.</p>
	<p><b>3750</b> Clevis pin, 3/8" x 1". 1 lb.</p>
	<p><b>6772-18</b> Universal clevis. Used on PB11001 &amp; PB11003. 3/8" x 24". 1 lb.</p>
	<p><b>P-105</b> Master cylinder pin. For deep/manual master cylinder. 65mm. 1 lb.</p>
	<p><b>PRE101</b> Universal pedal rod extension. 2 1/2" long, 3/8" hole. 3/8" x 24" 1 lb</p>
	<p><b>PRE104</b> Universal pedal rod extension. 1 1/2" long, 3/8" hole. 1 lb.</p>
	<p><b>PRE106</b> Universal 1 1/8" pedal rod extension. Both ends female 3/8" x 24. 1 lb</p>
	<p><b>PRE107</b> Universal pedal rod extension. 4 1/8" length. 3/8" x 24 rod. Eyelet ID 5/8". 1 lb</p>
	<p><b>PRE5564</b> Universal pedal rod extension. 4 3/4" long rod. Male &amp; Female = 3/8" x 24". 1 lb.</p>
	<p><b>PRE9</b> Universal pedal rod extension. 9" long. Male &amp; Female = 3/8" x 24". 1 lb.</p>
	<p><b>PRE7486</b> . 1 lb.</p>

# PEDAL ASSEMBLIES

**H**ave you ever tried to fabricate a new pedal or alter a pedal meant for a different application to try to get it to work on your project? Next time just choose from MBM's large selection of pedals designed to original spec and ready to bolt in.

**NEW  
ITEM!** **PRAUD**

Universal right angle booster bracket for use under dash. Perfect for tight spaces Non-coated for easier welding. 7 lbs

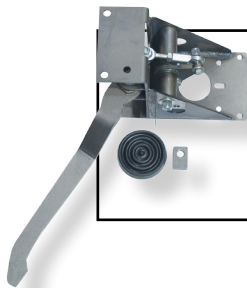

**TOP  
SELLER!** **PRAUF1**

Universal under-dash mount pedal. Laser cut with black powder-coated finish. Comes with PED1 installed. 8 lbs.



**PRAUM**

Universal frame mount manual brake pedal. Laser cut with black powder-coated finish. 10 lbs.

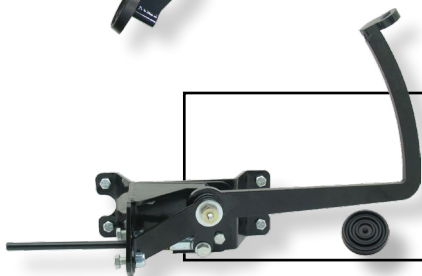

**PRAF4148**

Fits Ford 1941-48. Frame mount assembly. 6 lbs.

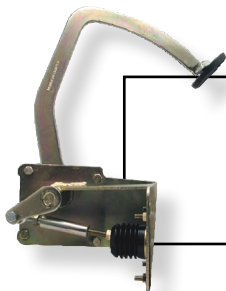

**PAC4954**

**NEW  
DESIGN!**

Fits Chevy car 1949-54. Frame mount assembly. New design helps to eliminate fitment issues. Laser cut. Black powder coat. 10 lbs.



**TOP  
SELLER!** **PRAU2831**

Universal frame mount pedal based on early Ford 1928-31 design. Laser cut with black powder-coated finish. This design also used in many other applications. 10 lbs.



**F3540**

Fits Ford 1935-40. Laser cut with black powder-coated finish. 7 lbs.



**PRAFMFT5356**

Fits Ford truck 1953-56. Frame mount assembly. Laser cut with black powder-coated finish. 11 lbs.



**PAC3536**

Fits Chevy car 1935-36. Frame mount assembly. 8 lbs.

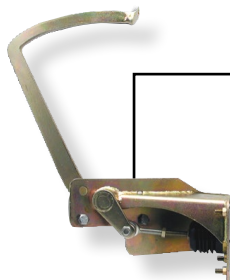



# PEDAL ASSEMBLIES

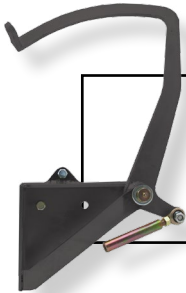

## PRAFMCT5559

Fits Chevy truck 1955-59. Frame mount assembly. Laser cut with black powder-coated finish. 8 lbs.



## PRAFMCT4754

Fits Chevy truck 1947-54. Frame mount assembly. Includes mounting bracket. Laser cut with black powder-coated finish. 8 lbs.

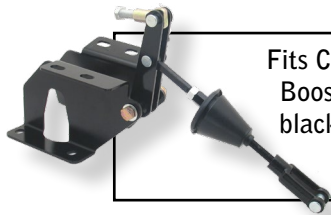

## CI5564BPR

Fits Chevy Impala 1955-64. Booster bracket. Laser cut with black powder-coated finish. 3 lbs.



## BPRP6570

Fits Dodge/Plymouth 1965-74 B & E-Body. Booster bracket. Laser cut with black powder-coated finish. 4 lbs.



## J7486

Fits Jeep CJ 1974-86. Booster bracket. Laser cut with black powder-coated finish. 4 lbs.

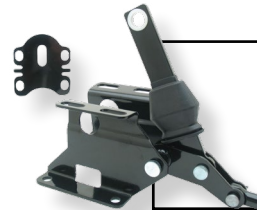

## FT5772BPR

Fits Ford 1957-72. Booster bracket. use with PBU5772 & PBU FT5772. Laser cut with black powder-coated finish. 3 lbs.



## BPRCT6772

Fits Chevy Truck 1967-72. Laser cut with black powder-coated finish. 4 lbs.



## BPRCT5559

1955-59 Chevy truck. Frame mount booster bracket. Laser cut with black powder-coated finish. 2 lbs.

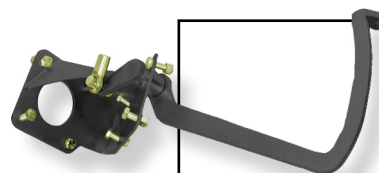

## F3334

Fits Ford 1933-34 Laser cut with black powder-coated finish. 7 lbs.

**SPECIAL ORDER ONLY**

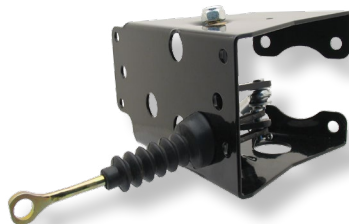

## BRFT12504

Fits Ford Bronco 1966-1977. Designed for use without modifying your Bronco and to allow clearance when used with fiberglass and low profile hoods. Includes firewall dust boot. Laser cut with black powder-coated finish. 10 lbs.



## PED1

Universal rubber pedal pad. Circular tread design. 1/2"-20 thread. 1 lb.



## BPAF6769PED

1967-69 Ford Mustang brake pedal for automatic cars. For use with PBU9007MC p.21 4 lbs.

# PROPORTIONING VALVES

**A** brake system is only as good as the sum of the parts. That's why MBM has a full selection of top-quality proportioning valves, metering blocks, and distribution blocks for you to choose from. Don't forget our full selection of kits that make installation a snap!

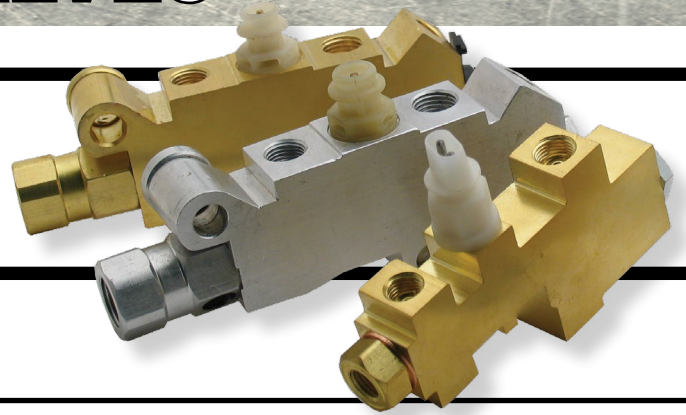

**Restoration  
Parts**



**PV5**  
Camaro 1969 Distribution Block. Exact copy of original. 1 lb.

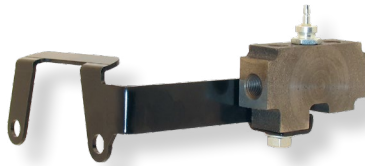

**PV67C**  
Fit Corvette 1967-68. Proportioning valve w/ bracket. Exact copy of original. 2 lbs.



**PV68**  
Fits Camaro 1967-69. proportioning valve with mounting bracket. 2 lbs.

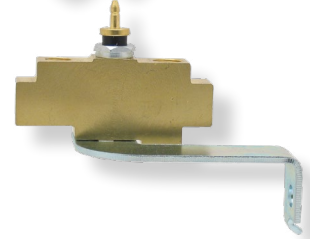

**PV69C**  
Corvette 1969 Distribution Block. Exact copy of original. 2 lbs.

**TOP  
SELLER!**



**PV2**  
Brass Combination valve for disc/drum application. 2 lbs.

**TOP  
SELLER!**



**PV4**  
Brass Combination valve for disc/disc application. 2 lbs.

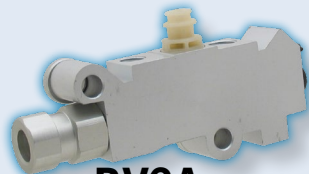

**PV2A**  
Aluminum Combination valve for disc/drum application. 1 lb.

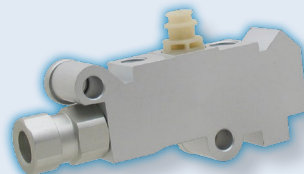

**PV4A**  
Aluminum Combination valve for disc/disc application. 1 lb.



**PV2C**  
Chrome Combination valve for disc/drum application. 2 lbs.



**PV4C**  
Chrome Combination valve for disc/disc application. 2 lbs.

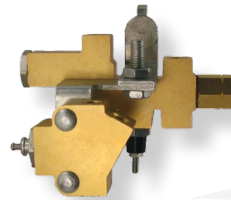

**PV6070MOP**  
Brass MOPAR disc/drum proportioning Valve. 3 lbs.

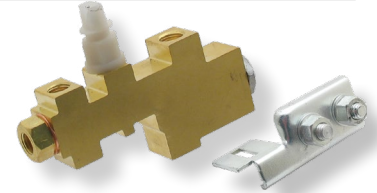

**PV6070FD**  
1965-73 Ford disc/drum OEM-Style. 2 lbs.

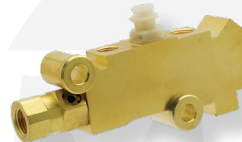

**PV14041636**  
DOT 5 COMPATIBLE Brass Govt. Vehicle proportioning valve. 2 lbs.

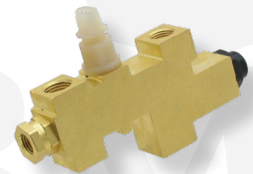

**PV8796J**  
Fits 87-96 Jeep Wrangler disc/drum & YJ. 2 lbs.



**PVC-B**  
Adjustable proportioning valve and distribution block all in one. Black 2 lbs.



**PVC-C**  
Adjustable proportioning valve and distribution block all in one. Chrome 2 lbs.

# PROPORTIONING VALVE KITS

## BRACKETS

Universal bottom-mount proportioning valve bracket. Available in zinc chrome or powder coating 1lb.

**PVB-B**

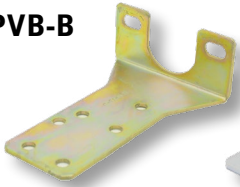

**PVB-BC**

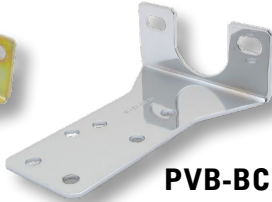

Universal left & right side proportioning valve bracket. Available in zinc or chrome 1lb.

**PVB-C**

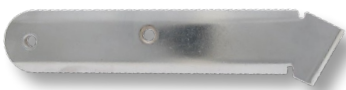

**PVB L/R**



## PROPORTIONING VALVE SPECIFICATIONS

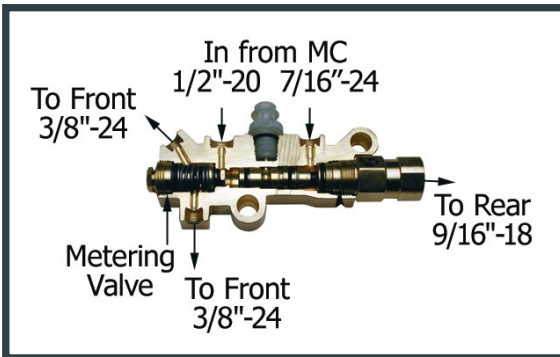

Don't have a smart phone or tablet? No worries go to [www.mbmbrakes.com](http://www.mbmbrakes.com) to find instructions, how-to's and other helpful information for installation and troubleshooting!



**RPV2** residual check valve 3/8-24" fittings. 2 lb. (blue)



**RPV10** residual check valve 3/8-24" fittings. 10 lb. (red)



**APV1** Universal adjustable proportioning valve. 3/8-24" fittings. 1 lb.



**PVM** Metering Block. 3/8-24" fittings. 1 lb



**PVP** Sensor wire for PV2/ PV4 prop valves. For Dashboard light. 1lb.



**PVT00L** Prevents valve from tripping during bleeding. 1lb.

## PLUMBING

LET MBM SUPPLY YOU WITH THE CORRECT LINES FOR YOUR PRODUCT. CHOOSE FROM STAINLESS OR MILD STEEL.

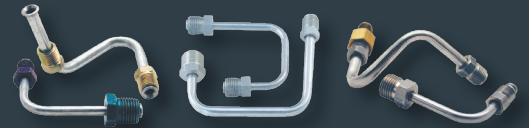

PVB-BT-2	Bottom mount steel lines: 9/16" and 1/2" ports.
PVB-BT-SS-2	Bottom mount stainless steel lines: 9/16" and 1/2" ports.
PVB-LT-2	Left-side mount steel lines: 9/16" and 1/2" ports.
PVB-LT-SS-2	Left-side mount stainless steel lines: 9/16" and 1/2" ports.
PVB-RT-2	Right-side mount steel lines: 9/16" and 1/2" ports.
PVB-RT-SS-2	Right-side mount stainless steel lines: 9/16" and 1/2" ports.
PVB-LT-1	Left mount steel lines for 3/8" ports.
BCK5005 Line Set	Includes all lines that come in our BCK5005. PVB-LT-3095, PVB-LT-30968, PVB-LT-6768, PVB-LT-69

## PROP VALVE KITS

COMPLETE KITS FOR LEFT SIDE, RIGHT SIDE, AND BOTTOM MOUNTING. INCLUDES PROP VALVE, MOUNTING BRACKET & LINES



LEFT MOUNT

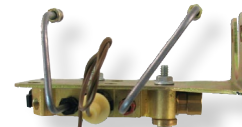

BOTTOM MOUNT



RIGHT MOUNT

### PV2 KITS - FOR DISC/DRUM SET-UP FITS 9/16" AND 1/2" PORTS.

PV2K-2	Brass left side mount kit. 4lbs.
PV2K-BM	Brass bottom mount kit. 4lbs.
PV2K-2RM	Brass right side mount kit. 4lbs.
PV2AK-2	Aluminum left side mount kit. 3lbs.
PV2AK-2BM	Aluminum bottom mount kit. 3lbs.
PV2CK-2	Chrome left side mount kit. 4lbs.
PV2CK-2BM	Chrome bottom mount kit. 4lbs.

### PV4 KITS - FOR DISC/DISC SET-UP FITS 9/16" AND 1/2" PORTS.

PV4K-2	Brass left side mount kit. 4lbs.
PV4K-2BM	Brass bottom mount kit. 4lbs.
PV4K-2RM	Brass right side mount kit. 4lbs.
PV4AK-2	Aluminum left side mount kit. 3lbs.
PV4AK-2BM	Aluminum bottom mount kit. 3lbs.
PV4CK-2	Chrome left side mount kit. 4lbs.
PV4CK-2BM	Chrome bottom mount kit. 4lbs.

# SPINDLES

**2627**

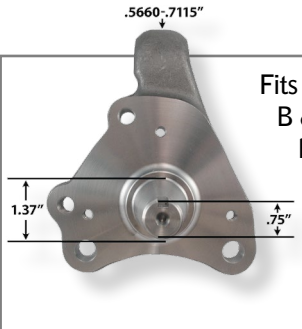

Fits 1962-74 Mopar B & E-Body. Stock height w/ caliper brackets. 3/4-16 nut. Exact reproduction of original. 18 lbs.

**3966151**

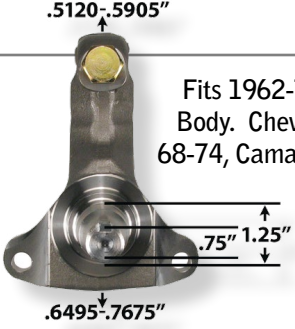

Fits 1962-74 GM A,F, & X Body. Chevell 64-72, Nova 68-74, Camaro 67-72. Stock height. 3/4-20 nut. Exact reproduction of original. 26 lbs.

**3966152**

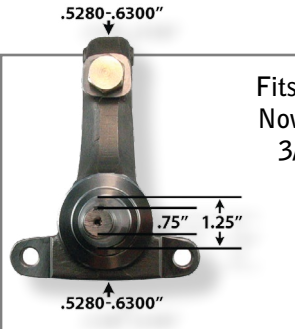

Fits 1962-67 Chevy Nova. Stock height. 3/4-20 nut. Exact reproduction of original. 24 lbs.

**155/156**

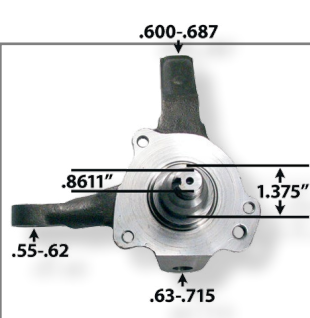

Mustang II universal stock height spindle. 13/16-20 Nut. 32 lbs.

**2-5557HD**

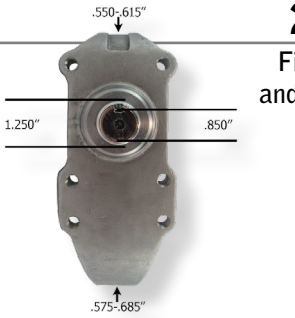

Fits 1955-57 GM and full-size Chevy. 2" drop TALL spindle. 3/4-20 nut. 24 lbs.

**3966155**

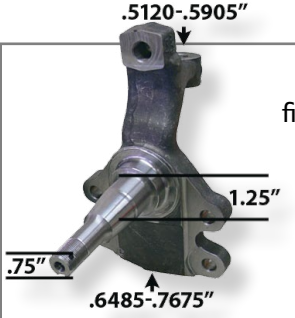

2" drop spindle fits 1964-74 GM A-Body. 3/4-20 nut. 26 lbs.

**1521**

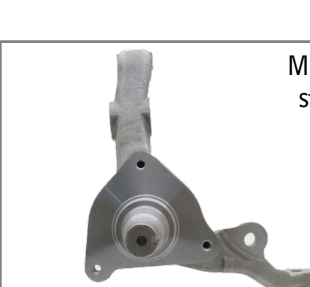

Mustang 1967-69 stock height disc brake spindles. 32 lbs.

**3966156KP**



Kingpin set and hardware for 1928-48 Ford. 6lbs

Kingpin set does not contain bushings.

**3966151-BOLT**



Fits A, F, and X-Body stock spindles. 5/8-18 spindle bolt. 1 lb.

**REMEMBER**

You can always find our most up-to-date instructions for our products available for download at our website. Look in the "downloads" section at [www.mbmbrakes.com](http://www.mbmbrakes.com).



**SCAN**



## DUST SHIELDS & BACKING PLATES



**BP7679**

Fits 1976-79 Ford Bronco and F-150. Improved design to improve airflow. Galvanized steel. 2 lbs.



**3966155DS**

Dust Shield specifically designed for use with our 3966155 drop spindle.

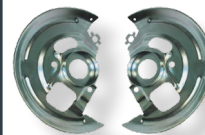

**BP151**

Fits 1964-72 GM A, F, & X-Body w/3966151 spindle. Exact reproduction of original. 2 lbs.



**BP302**

Mopar backing plates for 2627 spindle. Exact reproduction of original. 2lbs.

### WHICH BEARINGS AND SEALS SHOULD I CHOOSE FOR MY SPINDLE SET?

Spindle	Inner Bearing	Outer Bearing	Seal
3966151	A6	A2	8705-S
3966152	A6	A2	8705-S
3966155	A6	A3	8871
2-5557HD	A6	A3	8871
2627	A17	A2	5121
155/156	A13	A12	6815
1521	A13	A12	6815

# CALIPER BRACKETS & CALIPERS

## CALIPER BRACKETS

### CB5558+ CBS5558



Fits 1955-58 full -size Chevy: Bel Air, Biscayne, Impala, 150, 210. 2 lbs.

### CB5964+ CBS5964



Fits 1959-64 full-size Chevy: Bel Air, Biscayne, Impala, 150, 210. 2 lbs

### 3966155B



Caliper bracket designed for use with our 3699155 and 3966151 spindles.

### 3966155B-14

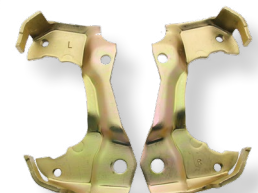

Used by A, F, X Body Disc Brake Kits using 14" rims. With GM Part Numbers.

### CB7191

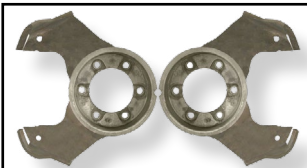

Fits 1971-91 Ford Bronco, Jeep Ranchero, and Jeep. 8 lbs.

### CB7478



Mustang II bracket fits 2-155/165 and 155/156 spindles using 7" GM caliper. 2 lbs.

### CB6675



Fits 1966-75 Ford Bronco. Each bracket is 7.1 lbs.

## WANT TO MAKE DISC-BRAKE INSTALLATION A LITTLE EASIER ON BOTH YOU AND YOUR CUSTOMERS?

Order some of our Instructional DVD's to include as an added value item for your customers. This easy to follow DVD can virtually eliminate tech calls and questions about your kits, saving you valuable time wasted on the phone answering questions and allowing you to focus on growing your business.



Have a tip for us? Got a great video you would like to show us? Give us an e-mail at [info@mbmbrakeboosters.com](mailto:info@mbmbrakeboosters.com)

### 4039+4040

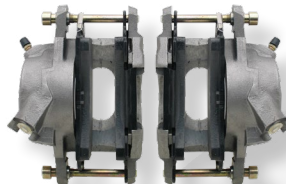

GM 7" single piston calipers. Fits GM 1964-72 A-Body, 1967-69 F-Body, 1968-74 X-Body, Mustang II, and 1955-64 full-size Chevy stock height. Loaded. 24 lbs.

### 4103+4104



Fits Mopar B-Body 1967-72, Mopar E-Body 1970-74,. Kelsey-Hayes slide-type single piston caliper. Loaded. 24 lbs.

### NR172+NR173 METRIC

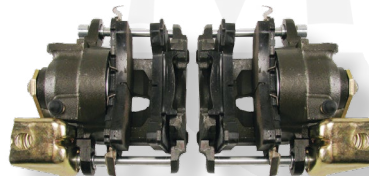

Fits GM A, F, and X-Body. Rear single-piston calipers. Loaded. 24 lbs.

### 4125+4126 METRIC

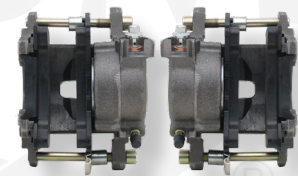

GM 5" single piston calipers. Works with 2" drop vehicles. Fits GM A-Body 1964-72, GM F-Body 1967-69, GM X-Body 1968-74, Mustang II and Full-size Chevy 1955-64. Loaded. 24 lbs.

# ROTORS, HOSES, & STEERING ARMS

## ROTORS

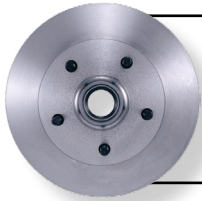

**5514**

Fits GM A-Body 1964-72, F-Body 1967-69, X-Body 1968-74, and Full-Size Chevy 1955-64. 13 lbs.



**5514LX+5514RX**

Cross-drilled and slotted. Fits GM A-Body 1964-72, F-Body 1967-69, X-Body 1968-74, and Full-Size Chevy 1955-64. Sold in sets. 26 lbs.

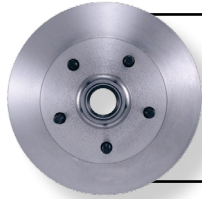

**5314**

Fits Mopar 1962-74 as well as many early Ford applications. 13 lbs.

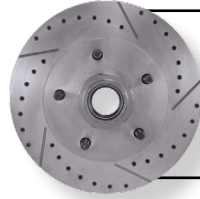

**5314LX+5314RX**

Cross-drilled and slotted. Fits Mopar 1962-74 as well as many early Ford applications. Sold in sets 26 lbs.

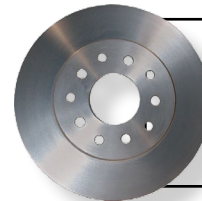

**5560-10**

Fits Ford, GM 5-Stud, Mustang II and many street-rod applications. 14 lbs.

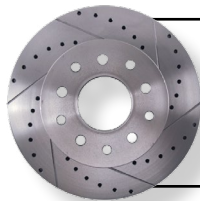

**5560-10LX+5560RX-10**

Cross-drilled and slotted. Fits Ford, GM 5-Stud, Mustang II and many street-rod applications. 14 lbs.

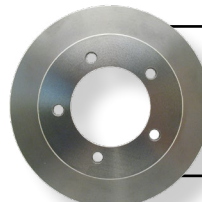

**5568BP**

Fits Ford trucks 5 on 5 1/2 stud pattern. Fits our DBK9TRK 14 lbs.



**55009**

Fits our big brake kit 6472BB. A, F, & X Body. 13 Inch Rotor. 14 lbs.

## HOSES

**HSDBK-10MM / HSDBK-7/16**



Rubber caliper brake hose. 18" length. Available in 10mm and 7/16 diameter. Sold in sets. 1 lb.

**HSDBKSS-10MM / HSDBKSS-7/16**



Braided stainless-steel caliper brake hose. 18" length. Available in 10mm and 7/16 diameter. Sold in sets. 1 lb.

## STEERING ARMS

**NEW ITEM! SA6974**



Steering arms for use with 1969-74 Chevy Nova and Camaro. 4 lbs.

**NEW ITEM! SA6472**



Steering arms for use with 1964-72 Chevy Chevelle. 4 lbs.

# STEERING & SUSPENSION

## RPP7478



Mustang II universal power rack and pinion. 20 lbs.

## RPM7478

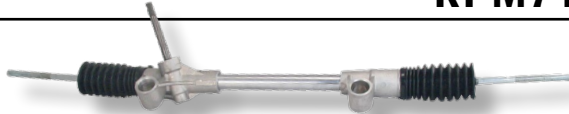

Mustang II universal manual rack and pinion. Splined shaft. Steering shaft connector is 14mm and is D shaped. 20 lbs.

## GM689



Universal multi-pattern hub. Socket cap screws, not studs. Fits Ford, GM, and many other applications. Uses A12 and A13 bearings, 6815 seal, and 20618103 dust cap. Studs sold separately. 12 lbs.

## GM690



Universal multi-pattern hub. Socket cap screws, not studs. Fits Ford, GM, and many other applications. Uses A2 and A6 bearings, 8705S seal, and 20618103 dust cap. Studs sold separately. 12 lbs.

## SB140



Vega steering box. Great for hotrod projects. For use in vehicles weighing under 2800 lbs. 13 lbs.

## SBPA140

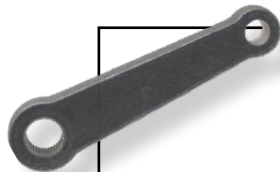

Pitman arm for use with our Vega steering box. 2 lbs.

## SB140BR

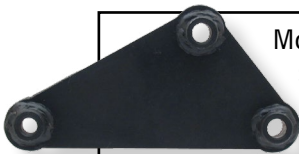

Mounting bracket for use with our Vega steering box. 2 lbs.

## SUSPENSION

### UCA856/857



Mopar B-Body 1967-72 control arms. 15 lbs.

### CA7478



Mustang II Upper and Lower Control Arms. Tubular steel with black finish. 8 lbs.

### CA6769



1967-69 Camaro / Firebird Upper and Lower Control Arms. Tubular steel with black finish. 9 lbs.

### CA6472



1964-72 Chevelle, GTO, 442, Buick GS, and others. Tubular steel with black finish. 9lbs

CONTROL ARMS ARE SOLD ONLY AS FULL PAIRS. IF YOU ARE INTERESTED IN BUYING ONLY THE UPPER OR LOWER CONTROL ARMS SEPERATELY, WE CAN ARRANGE IT. HOWEVER, YOU MUST PLACE A SPECIAL ORDER FOR US TO DO SO.

# HARDWARE, BEARINGS, & SEALS

## DISC BRAKE HARDWARE KITS

### HWK5558



Fits Full-Size Chevy 1955-64 stock height and 1955-57 2" drop kits. 3 lbs.

### HWK6272



Fits Mopar B-Body 1970-74 and E-Body 1962-74 height and drop height. 3 lbs.

### HWK6472



Fits GM A-Body 1964-72, F-Body 1967-69, X-Body 1968-74 stock and drop height. 3 lbs.

### HWK7478

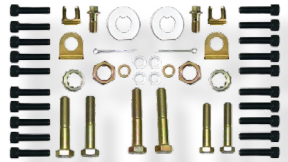

Mustang II stock and 2" drop kits. Includes GM and Ford hardware. 3 lbs.

## SEALS

Check our chart on Pg.28 in the Spindle section for an easy guide on which bearings to select for your spindle.

### 7934



Inner Diameter: 1.87"

### 5121



Inner Diameter: 1.94"

### 8871



Inner Diameter: 2.00"

### 6815



Inner Diameter: 1.94"

### 8705-S



Inner Diameter: 1.73"

## TECH NOTES

When wheel bearings are serviced, the old grease should first be removed and the bearings cleaned and inspected before being repacked with fresh grease. This will remove any contaminants from the hub that may cause problems later on, and eliminate any risk of incompatibility between the old and new grease. Don't forget to install new seals, as the old ones may have been damaged during removal.

## BEARINGS

### A2



Bore: 0.75", OD: 1.78", Cone part # LM11949, Cup part #: LM11910. 1 lbs.

### A3



Bore: 0.843", OD: 1.95", Cone part #: M12649, Cup part #: M12610. 1 lbs.

### A6



Bore: 1.25", OD: 2.32", Cone part # LM67048, Cup part #: LM67010. 1 lbs.

### A12



Bore: .861", OD: 1.78", Cone part # LM12749, Cup part #: LM12710. 1 lbs.

### A13



Bore: 1.37", OD: 2.32", Cone part # LM68149, Cup part #: LM68110. 1 lbs.

### A17



Bore: 1.37", OD: 2.36", Cone part # L68149, Cup part #: L68110. 1 lbs.

### A34



Bore: .843", OD: 1.78", Cone part # LM12748, Cup part #: LM12710. 1 lbs.

## WHEEL SERVICE KITS

A great item to add when your selling your customers new spindle kits, seals, or bearings. Our wheel service kits provide new dust caps, castle nuts, spindle washers, and cotterpins.



WSK5558



WSK6472



WSK6272



WSK7478



## **TROUBLESHOOTING** COMMON PROBLEMS

### **MASTER CYLINDER TEST:**

**NOTE:** This test requires a complete bleed of the brake system as the brake lines are removed, allowing air to enter.

### **TESTING THE MASTER CYLINDER:**

1. Remove the brake lines from the master cylinder ports
2. Block off the master cylinder brake line ports using the correct size inverted flare plugs or bolts. Dual port master cylinders that have ports on both sides need to have all four ports plugged. The protruding cone of the inverted flare seat in the master cylinder port is made of a soft material that can be easily deformed if over tightened. If using bolts, be sure to just snug the bolts so as not to damage the cone seal surface. This cone mates with the inverted flare opening of the brake lines. You may also drill a point into the end of the bolt to prevent damage to the cone. Most GM master cylinders use 9/16-18 threads for the front ports and 1/2-20 threads for the rear. Most Ford master cylinders use 3/8-24 threads for the front ports and 7/16-24 for the rear. Mopars 9/16-20 and 1/2-20
3. Apply constant pressure to the pedal. The pedal should remain firm, hard, and should not drop over time.
4. If the pedal is squishy, there may be air in the master cylinder. Bench bleed the master and test again.
5. If the pedal starts firm, but begins to drop over time while under constant pressure, the master cylinder should be replaced.

### **PROPORTIONING VALVE TEST:**

1. Use a test light by attaching a clip to a positive contact on the vehicle. Touch the point of the tester to the electrical connection of the combination valve. If the light does not come on, the valve system is operational and no further testing is required.
2. If the light comes on it is an indication that the pressure differential valve is stuck in the front or rear position.
3. Bleed the brake system to determine if the front or rear lines are blocked off. Set up one front wheel and one rear wheel for bleeding at the same time. Crack both bleeder screws and gently pump the pedal a few times. The blocked side will have very little fluid release, while an unblocked line will squirt fluid out of the bleeder.
4. Leave the bleeder for the unblocked lines open, while tightening the bleeder screws on the blocked side. This will allow pressure to build up on that side. Be sure to follow standard bleeding procedures to keep air from entering the system.
5. Slowly press the pedal with steady pressure several times until the light goes out, centering the differential valve. You may also hear a pop come from the proportioning valve. This is the metering valve returning to it's equalized position. When the light goes out, close the bleeder screw.

### **POWER BOOSTER TEST:**

If your brake pedal feels hard while the engine is running, it is likely your booster isn't operating correctly. If the booster is defective, do not attempt to disassemble or repair the booster. Doing so is unsafe and will void your warranty.

#### **Test 1:**

1. With the engine off, pump the brake pedal to remove any residual vacuum in the booster.
2. Hold pressure on the pedal while you start the engine. When the engine starts the pedal should drop about 1/4". This drop indicates the booster is working properly.

#### **Test 2:**

1. Run the Engine a couple of minutes.
2. Turn the engine off and press the pedal several times slowly. The first pump should be fairly low. The second and third pump should become slightly firmer. This indicates an airtight booster.

#### **Test 3:**

Start the engine and press the brake pedal, then hold the pedal while turning the engine off. If the pedal does not drop after holding the pedal for 30 seconds, the booster is airtight.

#### **Testing the Check Valve**

Disconnect the vacuum hose where it connects to the intake manifold. **DO NOT** disconnect the line from the booster.

#### **Verify vacuum volume.**

With the engine at normal operating temperature, there should be a minimum of 18" of vacuum. If vacuum is too low make sure that the engine is properly tuned and that there are no leaks or blockages in the vacuum lines.

### **AT MBM, CUSTOMER SERVICE IS A PRIORITY!**

I would like to thank Joel & your team for correcting the issue of my brake problem. Your product works great and I am pleased with it and the results. I sent a couple photos to Joel, one of your product in my CJ7 and another of the CJ7 that it went into. Again, Thank you! I am a satisfied customer and will not hesitate to use your products in the future.

~ R. Pelkey

**TOP SELLERS** TOP MOVING PRODUCTS

These top quality parts have proven to be big sellers. Are you carrying all of these products in your shop? Call us and add them today!

**PV4 DISC/DISC  
PROP VALVE**

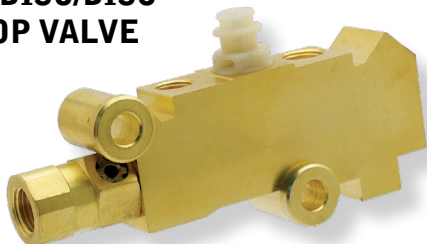

**PV2 DISC/DRUM  
PROP VALVE**

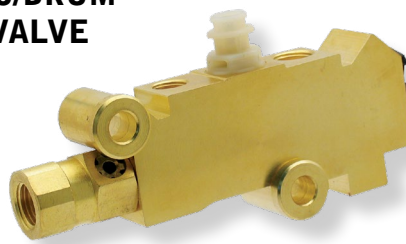

*Also available in kits with mounting brackets, plumbing, and wire sensor. See p. 27*



**MC2912H**

1 1/8" Bore. 9/16" and 1/2" ports on left side.

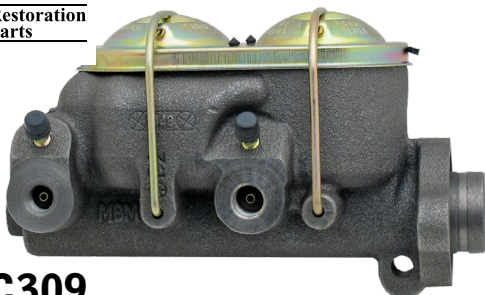

**MC309**

1 1/8" Bore. 9/16" and 1/2" ports on left side. Official GM Restoration Part.



**MC1321H**

1" Bore. 9/16" and 1/2" ports on left side

**SB140**

Vega Steering Box

**BRAND NEW!  
NOT A REMAN!**

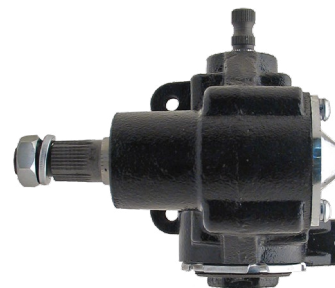

**BCK5005**

**TOP  
SELLER!**

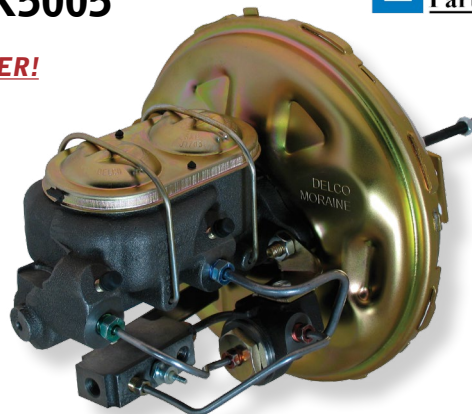

GM Restoration cast iron master cylinder with casting numbers.

We put the **POWER** in power brakes!

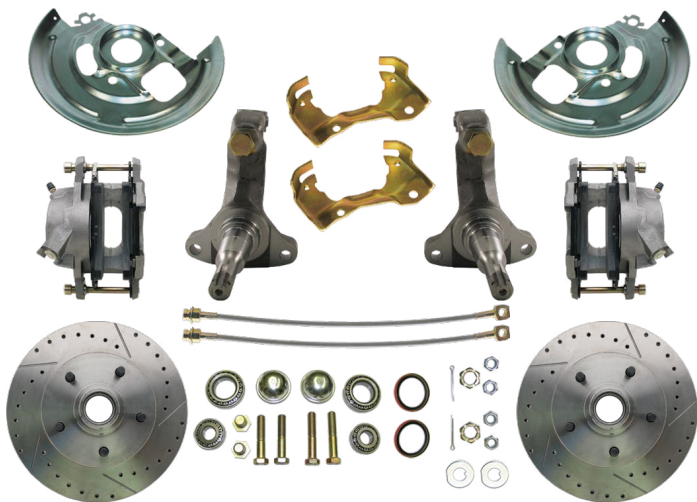

**DBK6472**  
**DBK6472LX**

Fits F-Body 1967-69, A-Body 1964-72, and X-Body 1968-74.

LX KIT SHOWN.  
ALSO AVAILABLE AS  
A STANDARD KIT.

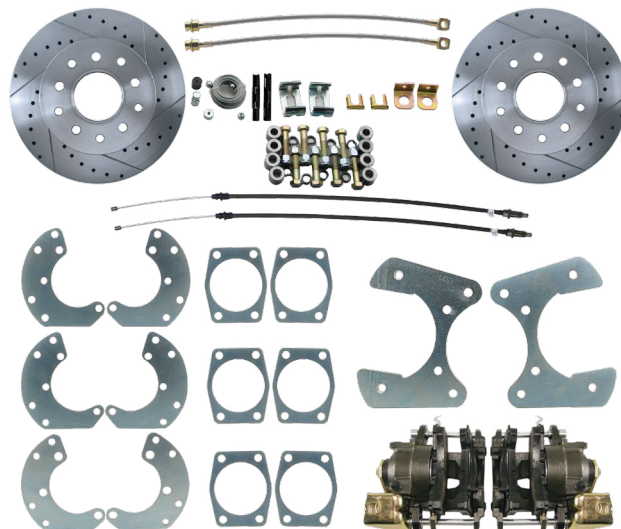

**DBK9**  
**DBK9LX**

Fits Ford 9" small bearing rear ends.

LX KIT SHOWN.  
ALSO AVAILABLE AS  
A STANDARD KIT.



**RPP7478**

Mustang II Power Steering Rack.  
See page 31

**PB11001**  
**DELCO MORAINE 11" POWER BOOSTER**



11" single diaphragm. Our top selling booster! Officially licensed!

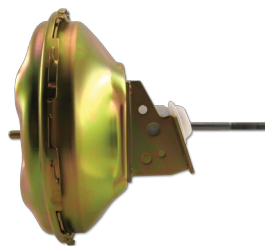

**PB11003**  
11" Single. No stamp



**PB8531**  
8" Dual Diaphragm



**PB7537**  
7" Dual Diaphragm



**PB7001**  
7" Single Diaphragm

# Become a MBM dealer today!



**SERVING YOU FROM OUR FACILITY IN  
ASHEVILLE, NC**



We here at MBM share and fully support the passion for Hot Rods and classic American Muscle Cars! That's why we are proud to be a part of these great organizations which help to ensure the continued protection and progression of the Hot Rod industry.

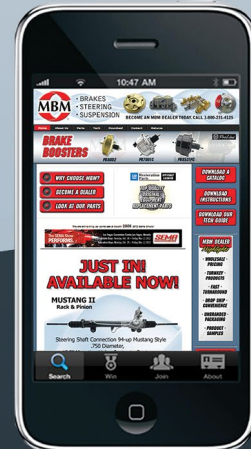

**SCAN  
ME!**



**27 MULVANEY STREET, ASHEVILLE NC 28803  
PH: 800-231-4125 / 828-258-0882 FAX: 800-331-1626/ 828-285-0877  
MBMBRAKES.COM**